



Instrumentação  
e Controle

# Catálogo



**NIVETEC INSTRUMENTAÇÃO E CONTROLE LTDA**

CNPJ: 66.747.627/0001-19

Tel: +55 (11) 2627-6600

E-mail: [comercial@nivetec.com.br](mailto:comercial@nivetec.com.br)

Rua das Flechas, 801 - Jardim Prudência, São Paulo - SP, 04364-030

[www.nivetec.com.br](http://www.nivetec.com.br)

# AquaSensors AquaClear DataStick Low-Level Turbidimeter

For accurate, real-time turbidity measurements

## Thermo Scientific AquaSensors AquaClear DataStick Low-Level Turbidimeter Measurement System

The Thermo Scientific™ AquaSensors™ AquaClear™ DataStick™ Low-Level Turbidimeter system delivers accurate turbidity measurements in drinking water applications and other process applications to monitor water quality. The AquaClear turbidimeter uses a pre-calibrated plug-in optical sensor head. The sensor is inserted into a sample chamber specifically designed to condition the water for turbidity measurements. The measurement chamber removes bubbles from the water so that solid particles can be accurately detected.

Maintenance costs are low with the AquaSensors AquaClear system. The lamp provides collimated white light for a minimum of three years and is easily changed. The volume of the measurement chamber is 135mL and requires a small amount of formazin to perform EPA-mandated calibrations, thus making the AquaClear turbidimeter a cost-effective investment.

The AquaSensors AquaClear system is offered in three convenient versions: a digitally networked version without a local display that can interface digitally with industrial control systems; a digitally networked version with a local display (AV38); and an analog version with a local display (AV88) that cannot digitally communicate to a host system but provides two analog outputs, two relays, and AC/DC power options. Both AV38 and AV88 local displays offer standard commands for calibration, configuration, diagnostics, and troubleshooting.



## Markets and applications

- Drinking water
- Filter monitoring membrane filtration
- Distribution monitoring
- Wastewater effluent (clarified)
- Packaged water systems
- Food & beverage processing
- Pharmaceutical process water

## Product benefits

- Meets standard methods for the examination water and wastewater, 22nd edition, method 2130, item B.
- Pre-calibrated measurement
- Plug & play sensor heads (digital versions only)
- Simple to operate

## AquaSensors AquaClear DataStick Low-Level Turbidimeter

The AquaSensors AquaClear digital version is part of the Thermo Scientific™ AquaSensors™ DataStick™ family of measurement products. The DataStick system can be configured with any AquaSensors sensor head and can communicate directly with industrial computer systems using a variety of communications adapters. This DataStick system can be digitally networked to a computer interface directly or to a local display (AV38 version only). This system provides universal conversion of sensor signals and interactive communications for measurement, calibration, configuration and diagnostics. Mounting adapters, junction boxes and recharge kits are available.

The AquaSensors AquaClear AV88 analog version is offered with two relays, 4-20 mA outputs and AC/DC power options. Both AV38 and AV88 local displays offer standard commands for calibration, configuration, diagnostics, and troubleshooting.

### Engineering specifications

1. The turbidity monitoring system is capable of functioning independently utilizing a local or remote display or in an expandable network of systems that can be calibrated, configured or diagnosed by a remote computer.
2. The turbidimeter continuously measures turbidity in the range of 0.001 to 100 NTU and is a microprocessor-based, on-line nephelometric instrument meeting all design and performance criteria specified by standard methods for the examination water and wastewater, 22nd edition, method 2130, item B.
3. Light is directed through the surface of the sample and the detector is immersed in the sample, eliminating glass windows and flow cells. Optical components are mounted in a sealed head assembly that can be removed easily for calibration/service.
4. The sample chamber is constructed of corrosion-resistant ABS plastic, and includes an internal bubble removal system to vent entrained air from the sample stream.
5. Accuracy is  $\pm 2\%$  of reading or  $\pm 0.015$  NTU (whichever is greater) from 0 to 10 NTU;  $\pm 5\%$  of reading from 40 to 100 NTU.
6. Displayed resolution is 0.001 NTU from 0 to 100 NTU.

7. User selectable signal averaging, bubble removal, alarm and diagnostics are included.
8. The sensor has a built-in pre-amplifier, universal signal conditioning electronics, universal engineering units conversion, and interactive communications with a host computer or display interface using one of several protocols including Modbus™ RTU, USB, or Ethernet.
9. The sensor has an integral temperature sensor to measure temperature independently.
10. All system components are C-UL-US Listed (367G E303570 E327739). For EMC immunity and emissions, system components are CE-Certified 89/336/EEC: CISPER 11, EN61000 (-4-2, -4-3, -4-4, -4-6, 4-8). Max Ambient 50°C.
11. The sensor is Thermo Scientific AquaSensors AquaClear low-range turbidimeter.



AquaClear system with digital AV38 display



AquaClear system with analog AV88 display

## Product benefits

- Meets standard methods for the examination water and wastewater, 22nd edition, method 2130, item B.
- 135 mL sample chamber
- 0.001 NTU resolution
- 3-year light source
- Compact mounting footprint
- Digital network interface
- Local interface with current outputs and relays
- Low flow rate
- Temperature measurement included
- Plug and play industrial communications adapters

Use this system when very accurate turbidity measurement is needed in drinking water and other critical water quality monitoring applications. Connect this system directly to a PLC (Programmable Logic Controller) for seamless integration with industrial control systems. Use any computer to display data, calibrate and customize the measurement. Report data with standard current outputs and set alarms with optional relays. Save on calibration cost with smaller volumes of formazin standard. Save space, time and money.

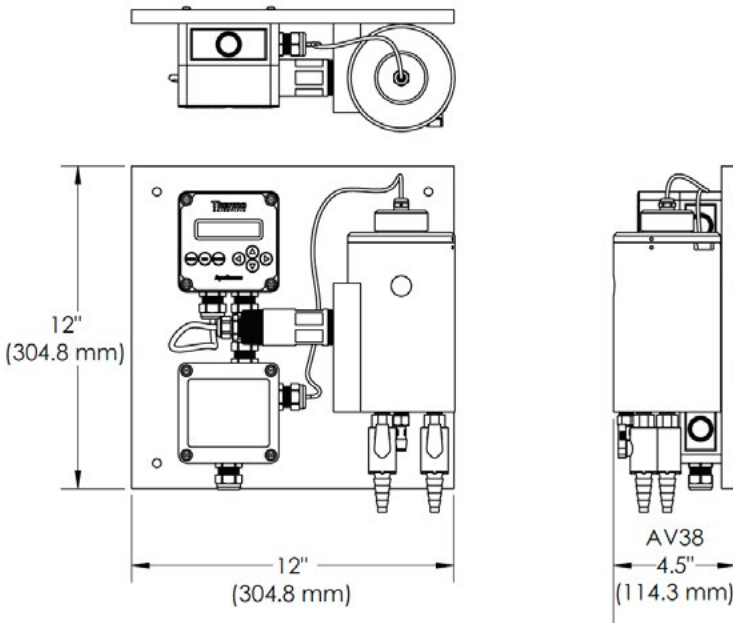

AV38 Engineering drawing

## AquaSensors AquaClear Turbidimeter

### Key component (AV38 version)

#### DataStick measurement system

Provides universal conversion of sensor signals and interactive communications for measurement, calibration, configuration and diagnostics



#### Optical sensor head

Yields accurate 24-bit data



#### Communications adapter

Plugs into the DataStick body to provide power and direct interactive communications with control systems



### AquaSensors AV38 Local Digital Monitor and Controller

2 line display and 7 key navigation. Data reporting with up to 2 current loops. 2 Form C relays. Digital communications



### Key component (AV88 version)

#### Optical Sensor Head

Accurate optical turbidity sensor and cable connection for AV88 controller



### AquaSensors AV88 AnalogPlus Universal Analyzer

2 line display and 7 key navigation. Data reporting with up to 2 current loops. 2 Form C relays. Analog communications



## AquaSensors AquaClear DataStick Low-Level Turbidimeter measurement system

### AV38 version

Description	Cat. No.
<b>Turbidity system</b>	<b>AQT-x-y-z</b>
Display configuration (x)	1 = Integral
AV38 configuration (y)	B = 2 current outputs, 2 relays and 24 VDC power D = 2 current outputs, 2 relays and 100-240 VAC power
Host Communications (z)	0 = None 4 = Modbus™ RTU 7 = Ethernet

### AV88 Version

<b>Model number</b>	AQT Turbidity measurement system. 0 to 100 NTU range. Precalibrated sensor, temperature measurement, sample chamber with bubble trap, lamp, junction box, mounting plate and AV88 local display.
<b>Display configuration</b>	1 Integral
<b>AV88 display configuration</b>	<p><b>DC</b> AQT1DC User interface with 2 current outputs, 2 relays. 24 VDC power.</p> <p><b>AC</b> AQT1AC User interface with 2 current outputs, 2 relays. 100 VAC to 240 VAC power.</p>
<b>AQT</b>	Turbidity measurement system part no.

## AquaSensors AquaClear DataStick Low-Level Turbidimeter measurement system specifications

Measurement system performance	Range: 0 to 100 NTU Resolution: 0.001 NTU Accuracy: ±2 % of reading or ±0.015 NTU whichever is greater. ±5 % of reading above 40 NTU
Operational environment	Water Temperature Range: -5°C to 50°C Air Temperature Range: -20°C to 60°C Maximum Flow Rate: 500 mL/min (7.9 gal/hr) Minimum Flow Rate: 250 mL/min (4 gal/hr)
Power requirements	Voltage Range: 24 VDC or 100-240 VAC Maximum Power: 8 W with AV38/88 DataStick and light source Typical Power: 6 W with AV38/88 DataStick and light source
Units Of Measure	Measurement Units: NTU Temperature Units: °C, °F

## AquaSensors AquaClear DataStick Low-Level Turbidimeter measurement system

### No display version

<b>Model number</b>	AQT Drinking water turbidity measurement system. 0 to 100 NTU Range. Precalibrated sensor, temperature measurement, sample chamber with bubble trap, lamp, junction box, and mounting plate.
<b>Reserved category</b>	<p><b>Power requirements</b> E 24 VDC power. F 100 VAC to 240 VAC power.</p> <p><b>DataStick communications</b> 4 Modbus RTU (24 VDC and RS485 terminal connections in AV38) 7 Ethernet, IP and Modbus, TCP (PoE RJ45 connector in AV38)</p>
<b>AQT</b>	Turbidity measurement system part no.

## AquaSensors AquaClear DataStick Low-Level Turbidimeter measurement system specifications (continued)

Construction	Light Source: White light (tungsten) Sample Chamber Material: ABS plastic Sample Chamber Volume: 135 mL Light Source Housing: Anodized aluminum Mounting Plate: 12 x 12 inches, 4 mounting holes Sensor Head Material: Quartz glass, anodized aluminium Weight: 5.6 lbs (2.5 kg)
Calibration	Sample: 1 point Zero: 1 point Temperature: 1 point
Interface	Display: 2 lines, 16 characters, 7 key menu navigation Current Outputs: 1 standard, 2nd optional Relays: 2 form C (optional)
Configuration Options	Sensor Filter: 0 to 100 seconds Temperature Filter: 0 to 100 seconds
Approvals And Ratings	Immunity & Emissions: CE certified 89/336/ EEC: CISPER 11, EN61000 (-4-2, -4-3, -4-4, -4-6, 4-8) Safety: cULus listed; 367G E327739

† Note: Typical at 25 °C performance unaffected by cable length

‡ Note: Class II DC power supply required

††Note: Turbidity and temperature are pre-calibrated at the factory

**Key component ordering information**

**AquaSensors AV38 Local Digital Monitor and Controller**

Description		Cat. No.	
DataStick measurement system		DS21-WA	
Turbidity sensor head		DW21	
Communications adapter		CA-b-nw-x-y	
Body material (b)	1	=	316 Stainless steel
	2	=	CPVC
	3	=	PEEK
Communications (nw)	2B	=	Modbus RTU
	7R	=	Ethernet
Cable length (x)	1	=	10 feet
	3	=	30 feet
Cable termination (y)	A	=	Stripped wire

Description		Cat. No.	
AV38 Local Monitor/Controller		AV38-v-w-x-y-z	
Current outputs (v)	B	=	One
	C	=	Two
Mounting (w)	B	=	¼ DIN NEMA 4X wall-mount enclosure
Communications (x)	0	=	None
	4	=	Modbus RTU (for Modbus + Profibus)
	7	=	Ethernet IP, Modbus TCP, TCP/ICP
Relays (y)	C	=	Two
Power (z)	1	=	24 VDC
	2	=	100 to 240 VAC

\*CA18R1A (316SS), CA28R1A (CPVC), CA38R1A (PEEK) keep available for USB option  
 Consult factory for additional configurations and accessories

**Accessory ordering information**

Description	Cat. No.
Lamp and cable	TDWLS00
Chamber lid	TDWCC01
Turbidity sample chamber	TDWSC01
Turbidity sensor head	DW21
Replacement lamp assembly, exchange of old lamp assembly with new lamp assembly	TDWLS01
Replacement lamp assembly, bulb preassembled into housing with cable	TDWLS02
4000 NTU formazin stock	AC45FZ
Cal stick validation	TDWCAL01
AV88 controller for AquaClear turbidimeter	TDWAV88
Sensor and cable for AV88 AquaClear turbidimeter	TDWSS88

Find out more at [thermofisher.com/water](http://thermofisher.com/water)