



Instrumentação  
e Controle

# Catálogo



**NIVETEC INSTRUMENTAÇÃO E CONTROLE LTDA**

CNPJ: 66.747.627/0001-19

Tel: +55 (11) 2627-6600

E-mail: [comercial@nivetec.com.br](mailto:comercial@nivetec.com.br)

Rua das Flechas, 801 - Jardim Prudência, São Paulo - SP, 04364-030

[www.nivetec.com.br](http://www.nivetec.com.br)

## Type 9950 Multichannel Transmitter

Member of the SmartPro® Family of Instruments



### Product description

The 9950 is a multi-channel, multi-sensor transmitter designed to meet and exceed the industry standards, and expectations for a small, compact, 1/4" DIN Transmitter. The power and versatility of the 9950 allows the use of up to six GF sensors to manage complex water treatment applications.

The 9950 analyzer supports ALL like sensors or a mix of any GF sensors. Sensor types and accessories supported by the 9950 are GF Flow (Frequency and/or digital S<sup>3</sup>L), pH/ORP,

Conductivity/Resistivity, Salinity, Temperature, Pressure, Level, Dissolved Oxygen, and any device that transmits a 4 to 20 mA signal when used with the 3-8058 iGo® Signal Converter.

The 9950 base unit comes complete with two each 4 to 20 mA output, two additional dual 4 to 20 mA output modules can be installed to increase the number of 4 to 20 mA outputs to a total of 6 outputs.

Four Conductivity sensor measurements are supported with either a single or dual channel conductivity module. If 6 conductivity sensors are required, the use of a 3-2850-X1-XX can be added to the main S<sup>3</sup>L input terminals.

The 9950 supports any one of the following relay modules:

- Four Mechanical Relay Module
- Two Mechanical and Two Solid State Relay Module
- Two Mechanical Relays and Four Binary Inputs Module

The 3-9950.393-3 Relay Module provides four binary inputs that are compatible with any open collector or mechanical contacts, such as level switches, flow switches, pressure switches or other devices.

The 9950 offers advanced features such as derived functions, advanced multiple relay modes (Boolean logic), and timer-based relay functions.

The 9950 Modbus Module allows for remote access to primary and secondary measurements, derived functions, status of current loop outputs and relays, over a serial RS485 Modbus automation network.

## Features

- Up to six different sensor types can be combined in one instrument
- Derived measurements - Delta, Sum, ratio, % recovery, % reject , % passage
- Advanced boolean logic -A | B | C, A & B & C, A | (B & C), A & (B | C)
- Single and Dual Channel Direct Conductivity/Resistivity Modules
- Up to four on board relays via optional modules, and up to 4 external DIN Rail mounted Relays via optional 8059 module (six input option only)
- Optional Modbus RTU Module for connections to Serial RS485 automation networks
- Configurable display
- Multiple language support for English, French, German and Spanish



## Applications

- Wastewater Treatment
- Membrane and Media Filtration
- RO / DI Skids and Systems
- Chemical Manufacturing/Addition
- Metal and Plastic Finishing
- Fume Scrubber
- Cooling Towers
- Horticulture/ Vertical Farming
- Chemical Dosing/Injection
- Aquatic Life Support
- Pools & Fountains
- Rinse Tanks
- Chemical Neutralization
- Mining

## Specifications

### General

Input Channels 9950-1,2	Two frequency or two (S <sup>3</sup> L) inputs. Plus up to four Binary inputs
Input Channels 9950-10, 11	One frequency and five (S <sup>3</sup> L) inputs, two frequency and four (S <sup>3</sup> L) inputs or six (S <sup>3</sup> L). Plus up to four Binary inputs

### Enclosure and Display

Case Material	PBT
Window	Shatter-resistant glass
Keypad	4 buttons, injection-molded silicone rubber seal
Display	Dot matrix, LCD
Indicators	Two horizontal digital bar graphs, four LED relay status indicators
Update Rate	1 s
LCD Contrast	5 settings
Size	¼ DIN

### Mounting

Panel	¼ DIN, ribbed on four sides for panel mounting clip inside panel, silicon gasket included
Wall	Wall Mount enclosure (sold as an accessory)

### Terminal Blocks

Pluggable Screw type	Use minimum 105 °C rated wire
----------------------	-------------------------------

### Torque Ratings

All connectors	0.49 Nm (4.4 lb-in.)
----------------	----------------------

### Connector Wire Gauge

Power, Loop	12 to 22 AWG; 0.34 mm <sup>2</sup> to 4 mm <sup>2</sup>
Freq/S <sup>3</sup> L	16 to 22 AWG; 0.34 mm <sup>2</sup> to 1.5 mm <sup>2</sup>

### Environmental

#### Ambient Operating Temperature

DC Power	-10 °C to 70 °C	14 °F to 158 °F
AC Power	-10 °C to 60 °C	14 °F to 140 °F
Storage Temp	-15 °C to 70 °C	5 °F to 158 °F
Relative Humidity	0 to 100% condensing for (front only); 0 to 95% non-condensing (rear panel)	
Maximum Altitude	4,000 m (13,123 ft)	
Enclosure Rating	NEMA 4X/IP65 (front face only)	

### Performance Specifications

System Accuracy	Primarily dependent upon the sensor
System Response	Primarily dependent upon the sensor. Transmitter adds a maximum of 150 ms processing delay to the sensor electronics. Minimum update period is 100 ms System response is tempered by the display rate, output averaging and sensitivity feature
Conductivity/Resistivity input directly from GF Conductivity/Resistivity electrodes via Direct Conductivity/Resistivity Module, 3-9950.394-1, or 3-9950.394-2, or 3-2850-51 electronics (Integral mount), 3-2850-61, and 3-2850-63 electronics (universal field mount)	

### Electrical Requirements

#### Power to Sensors

Voltage	+4.9 to 5.5 VDC @ 25 °C, regulated
Current	30 mA
Short Circuit	Protected
Isolation	Low voltage (< 48 V AC/DC)

## Power Requirements

DC (3-9950-1, 3-9950-10)	24 VDC nominal (12 to 32 VDC, $\pm 10\%$ regulated), UL 60950-1 or UL 61010-1 Power Supply rated for operation at 4000 m altitude
AC (3-9950-2, 3-9950-11)	100 to 240 VAC, 50 to 60 Hz, 24 VA
Maximum current	200 mA (without optional relay module)* 500 mA (with optional relay module)*
*The current draw of the other modules and the sensors are minimal	
Current Loop (active)	12 to 32 VDC, $\pm 10\%$ regulated, 4 to 20 mA (30 mA max.)
Overvoltage protection	48 Volt Transient Protection Device (for DC ONLY)
Current limiting for circuit protection	
Reverse-Voltage protection	

## Input types

Digital (S3L), Open Collector or AC Frequency (flow sensors)	
4 to 20 mA input via the 3-8058-1 single input or 3-8058-2 double input iGo Signal Converter	
pH/ORP input via the Digital (S3L) output from the 2751 pH/ORP Smart Sensor Electronics	
Conductivity/Resistivity via the Digital (S3L) output from the optional direct Conductivity Module or 2850 Conductivity/Resistivity Sensor Electronics	
Sensor types	Flow, pH/ORP, Conductivity/Resistivity, Pressure, Temperature, Level/Volume, Salinity, Dissolved Oxygen, Other (4 to 20 mA)

## Sensor Input Specifications

Digital (S3L)	Serial ASCII, TTL level, 9'600 bps
Frequency Flow Sensors	0.5 to 1'200 Hz
Sensitivity (for coil type sensors)	80 mV @ 5 Hz, gradually increasing with frequency to 2.5 V
Freq. Range (for square wave type sensors)	0.5 Hz to 1'200 Hz @ TTL level input or open collector
Direct Conductivity Module - 3-9950.394-1 (single input) and 3-9950.394-2 (dual input)	
Accuracy	Conductivity $\pm 2\%$ of Reading Temperature 0.5 °C
Resolution	Conductivity 0.1% of Reading Temperature <0.2 °C
Update Rate	2.5 Seconds Single Channel, 5 Seconds Dual Channel
Compatible Sensors	All GF Conductivity Sensors

## Current Loop Specifications

Current Loop Out	ANSI-ISA 50.00.01 Class H (Passive, external voltage required)		
Voltage	12 to 32 VDC, $\pm 10\%$ regulated, UL 60950-1 or UL 61010-1 Power Supply rated for operation at 4000 m altitude		
Max. Impedance	250 $\Omega$ @ 12 VDC	500 $\Omega$ @ 18 VDC	750 $\Omega$ @ 24 VDC
Span	3.8 to 21 mA		
Adjustable Span, Reversible			
Error Condition	Selectable error condition 3.6 or 22 mA or None		
Analog Outputs	2 Passive 4 to 20 mA Outputs in Base Unit or 2 or 4 passive current loops by optional module(s)		

## Relay Specifications

Dry Contact Relays (3-9950.393-1, 3-9950.393-2, and 3-9950.393-3)	
Type	SPDT
Form	C
Max. Voltage Rating	30 VDC or 30 VAC
Max. Current Rating	0.050 A resistive
Solid-State Relays (3-9950.393-2)	
Type	SPDT
Form	C
Max. Voltage Rating	30 VDC or 30 VAC

## Relay Specifications

Max. Current Rating	0.050 A resistive
Hysteresis	Adjustable (absolute in Engineering Units)
On Delay	9'999.9 seconds (max)
Cycle Delay	99'999 seconds (max)
Test Mode	Set On or Off
Maximum Pulse Rate	0 to 300 pulses/minute
Proportional Pulse	0 to 300 pulses/minute
Volumetric Pulse Width	0.1 to 3'200 s
PWM Period	0.1 to 320 s

## Binary Input (3-9950.393-3)

Input Voltage Range (without damage)	-5 VDC to 30 VDC (No operation below 0 VDC)	
Max. Current Rating	6.0 mA	
Max. Voltage Rating	30 VDC	
Maximum Input Voltage for signal "Off" (low or "0")	1.5 VDC	
Minimum Input Voltage for signal "On" (high or "1")	3.0 VDC	
Maximum Current Draw for Signal "0" (low)	≤ 500 μA DC	
Minimum Current Draw for Signal "1" (high)	500 μA	
Typical Current Draw for Signal "1" (high)	6.0 mA at 30 VDC, 4.8 mA at 24 VDC, 2.4 mA at 12 VDC, 1.0 mA at 5 VDC	

## Display Ranges

pH	-1.00 to 15.00 pH	
pH Temp.	-99 °C to 350 °C	-146 °F to 662 °F
ORP	-1'999 to +1'999.9 mV	
Flow Rate	-9'999 to 99'999 units per second, minute, hour or day	
Totalizer	0.00 to 99'999'999 units	
Conductivity	0.0000 to 99'999 μS, mS, PPM and PPB (TDS), kΩ, MΩ	
Cond. Temp.	-99 °C to +350 °C	-146 °F to 662 °F
Temperature	-99 °C to +350 °C	-146 °F to 662 °F
Pressure	-40 to 1000 psi	
Level	-9'999 to +99'999 m, cm, ft, in, %	
Volume	0 to 99'999 cm <sup>3</sup> , m <sup>3</sup> , in <sup>3</sup> , ft <sup>3</sup> , gal, L, lb, kg, %	
Salinity	0 to 100 PPT	
Dissolved Oxygen	0 to 50 mg/L, 0 to 200%	

## Shipping Weights

Base Unit	0.63 kg	1.38 lb
Relay Module	0.19 kg	0.41 lb
Single Module	0.075 kg	0.16 lb
Dual Channel Module	0.075 kg	0.16 lb
Modbus Module	0.075 kg	0.16 lb

## Standards and Approvals

CE, UKCA, UL, CUL, FCC

RoHS Compliant, China RoHS

Manufactured under ISO 9001, ISO 14001, and ISO 45001

## Dimensions

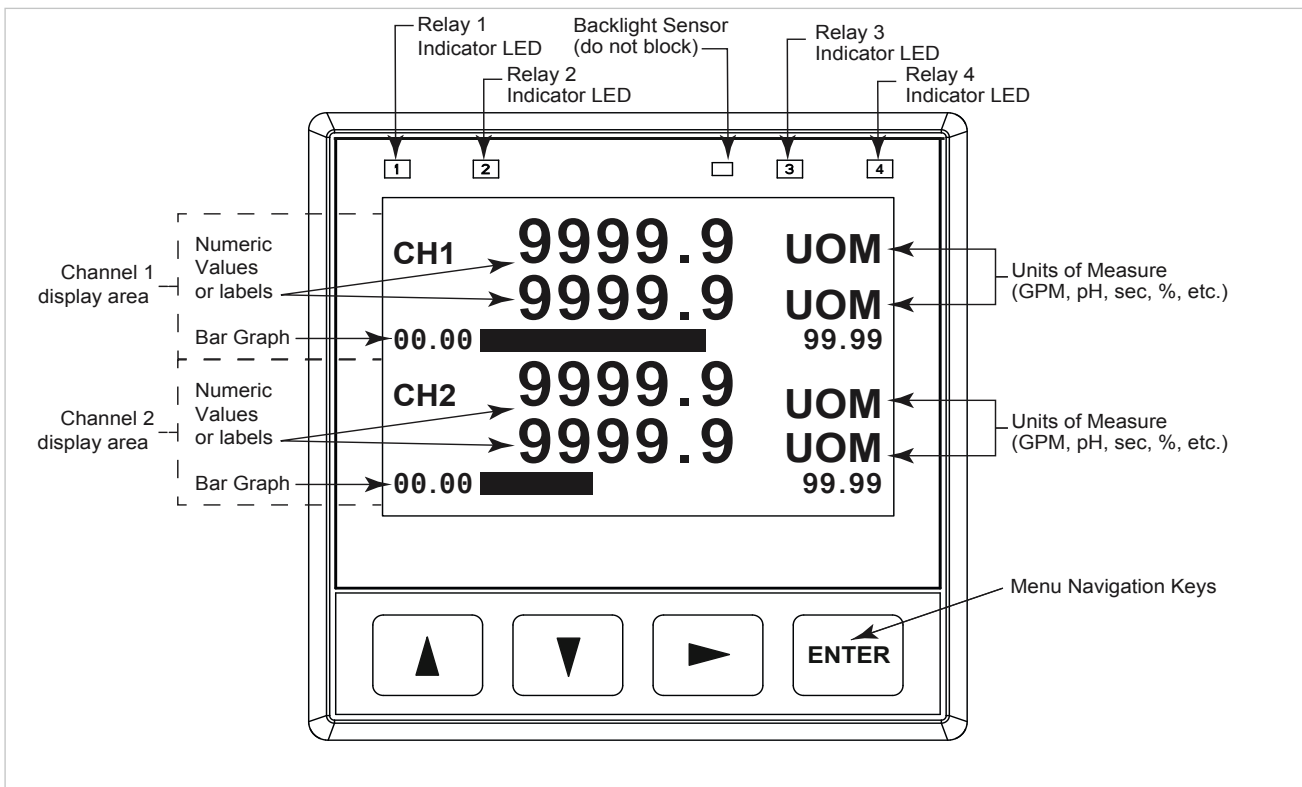
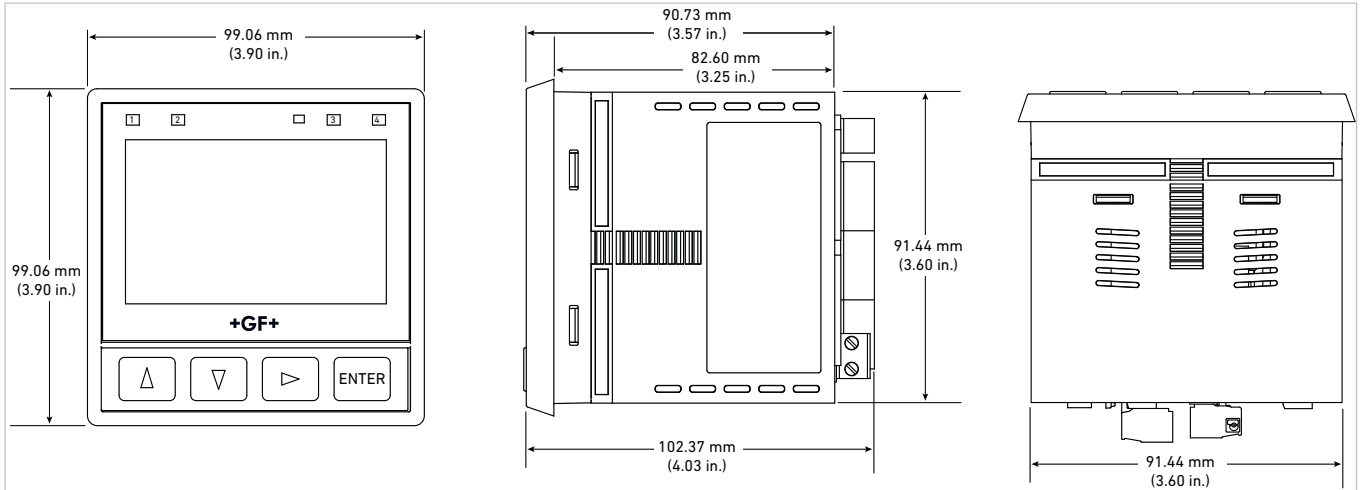

Sensor type	Freq Output	Digital (S <sup>3</sup> L) Output	Requires 8058
515	X		
525	X		
2000	X		
2100	X		
2250		X	
2350		X	
2450		X	
2507	X		
2536	X		
2537-5		X	
2540	X		
2551	X	X	
2552	X	X	
258X	X	X	
U1000 V2	X		
U3000	X		
2260			X
2270			X
2290			X
2291			X
2610-51		X	
2751		X	
2850-51-XX*		X	
2850-61*		X	
2850-63*		X	

\* No conductivity module required

Channels 1 through 6 are identical.

The 9950 allows a total of six sensors to be used at a time and is compatible with all GF products listed.

- pH/ORP electrodes require the type 2751 DryLoc<sup>®</sup> Sensor Electronics (sold separately)
- Conductivity/Resistivity measurement requires the type 2850 Conductivity/Resistivity electronics or a single or dual conductivity module and proper conductivity sensor (sold separately).

## System Overview

### Panel or Wall Mount

**Type 9950 Transmitter**  
(Includes mounting bracket and panel gasket)



### Automation System

**Type 9950 Transmitter with Modbus Module**

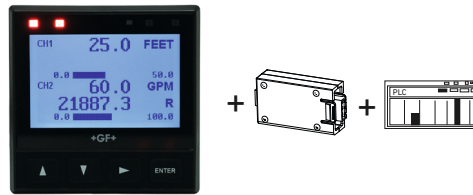

GF Sensors - Flow, Level, Temperature, Pressure, DO  
Use one input from sensor options below

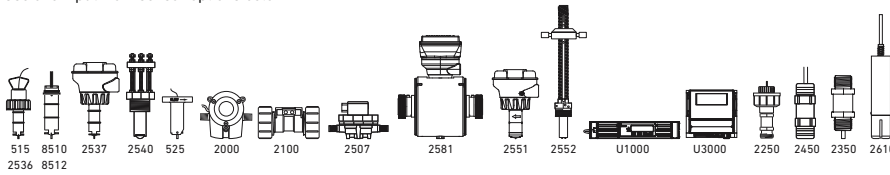

4-20mA level transmitter  
Use 8058 i-Go™ Analog to S<sup>3</sup>L Module for signals other than 4-20 mA

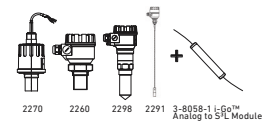

GF Sensors - pH/ORP  
Use one input from sensor options below with 2751 pH/ORP Smart Sensor Electronics

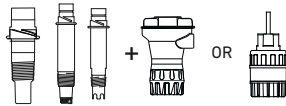

GF Wet-Tap Electrode type 2756, 2757 and 3719 Wet-Tap with 2751 pH/ORP Smart Sensor Electronics

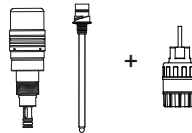

GF Sensors - Conductivity/Resistivity and Salinity Sensors Electrodes

Use either a single or dual input conductivity module one input and any GF conductivity sensor (3-2819 - 2823 or 2839 - 2842 ) from electrode options below with Conductivity Module or 2850 Sensor Electronics



GF Fittings - See individual sensor data sheets

All Sold Separately

## Modular Design Changeable I/O Cards

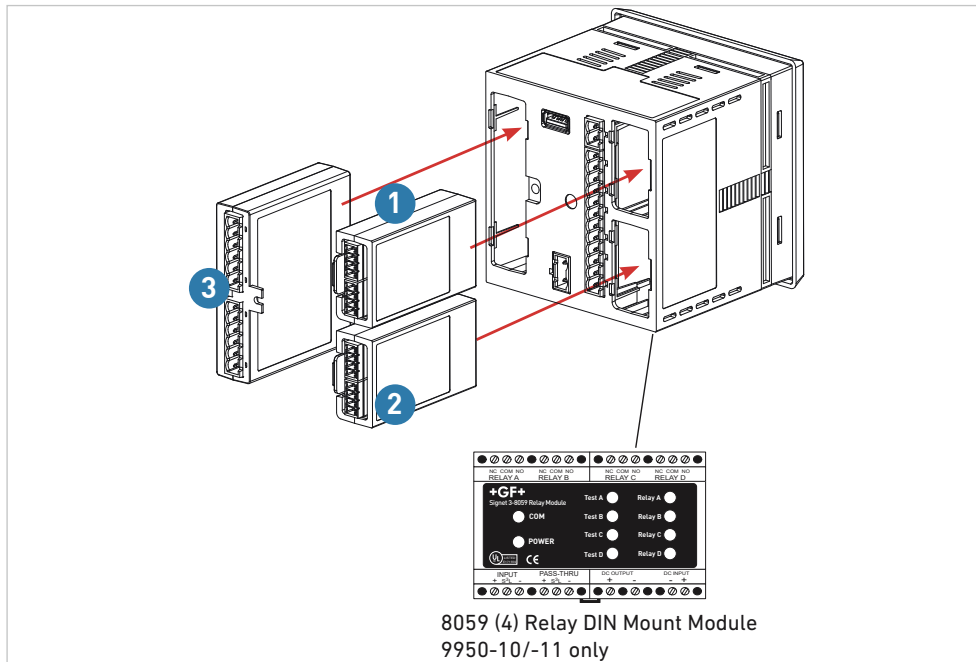

- 1 Module 1 Access Point
- 2 Module 2 Access Point
- 3 Relay Module Access Point

### (1) & (2) Module 1 Access Point

3-9950.398-2	Dual Channel 4 to 20 mA output module
3-9950.394-1	Single Channel Conductivity module
3-9950.394-2	Dual Channel Conductivity module
3-9950.395-M	Modbus Module *

### (3) Relay Module Access Point

3-9950.393-1	Mechanical relays
3-9950.393-2	Mechanical relays and 2 solid state relays
3-9950.393-3	Mechanical relays and 4 binary inputs

\* Only one module required for all outputs

## Ordering Information

Mfr. Part No Code	Description
<b>9950 Base Unit - Multi-Channel, Multi-Parameter, AC Power and DC Power</b>	
3-9950-1 159 001 841	9950 Base Unit – Two Channel Multi-Parameter Inputs, Two 4 to 20 mA Outputs, Panel Mount, 12/24 VDC
3-9950-2 159 001 842	9950 Base Unit – Two Channel Multi-Parameter Inputs, Two 4 to 20 mA Outputs, Panel Mount, 12/24 VDC or 100 - 240 VAC
3-9950-10 159 002 075	9950 Base Unit – Six Channel Multi-Parameter Inputs, Two 4 to 20 mA Outputs, Panel Mount, 12/24 VDC
3-9950-11 159 002 076	9950 Base Unit – Six Channel Multi-Parameter Inputs, Two 4 to 20 mA Outputs, Panel Mount, 12/24 VDC or 100 - 240 VAC

### Optional Accessory Modules

3-9950.393-1 159 310 268	Relay Module with 4 Mechanical Relays
3-9950.393-2 159 310 269	Relay Module with 2 Mechanical and 2 Solid State Relays
3-9950.393-3 159 310 270	Relay Module with 2 Mechanical Relays and 4 Binary Inputs
3-9950.394-1 159 001 846	Single Channel Direct Conductivity/Resistivity Module
3-9950.394-2 159 001 847	Dual Channel Direct Conductivity/Resistivity Module
3-9950.395-M 159 001 905	Modbus Module
3-9950.398-2 159 001 848	Dual Channel 4 to 20 mA Current Loop Output Module
3-8059-4* 159 000 772	12 to 24 VDC External DIN Mount, 4 Relay Module
3-8059-4AC* 159 000 773	100 to 240 VAC External DIN Mount, 4 Relay Module with 24 VDC Output

\* Not compatible with the 9950-1 or 9950-2

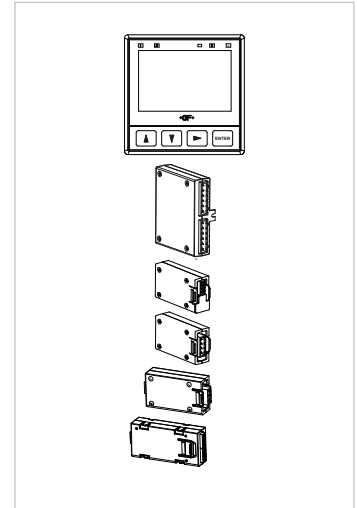

## Accessories and Replacement Parts

Mfr. Part No	Code	Description
3-5000.399	198 840 224	5 x 5 inch Retrofit Adapter
3-8050.392	159 000 640	CR200 ¼ DIN Retrofit Adapter
3-8050.396	159 000 617	RC Filter Kit (for relay use), 2 per kit
3-8058-1	159 000 966	i-Go® Signal Converter, wire-mount
3-8058-2*	159 000 967	i-Go® Signal Converter, rail-mount
3-9950.391	159 310 278	Connector Kit, In-Line, 9950 Transmitter
3-9950.392	159 310 279	Relay Module Connector Kit, 9950 Transmitter
3-9900.392	159 001 700	Wall Mount Enclosure Kit
3-9000.392-1	159 000 839	Liquid Tight Connector Kit, NPT (1 pc.)

\* Not compatible with the 9950-1 or 9950-2

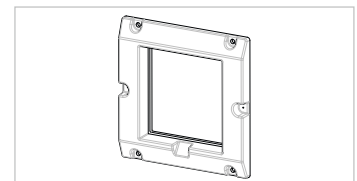

3-5000.399

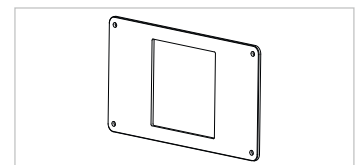

3-8050.392

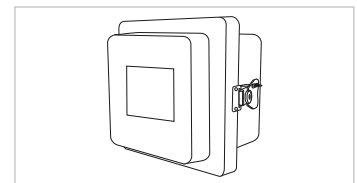

3-9900.392

## Wiring information

### Frequency sensors and S<sup>3</sup>L sensors

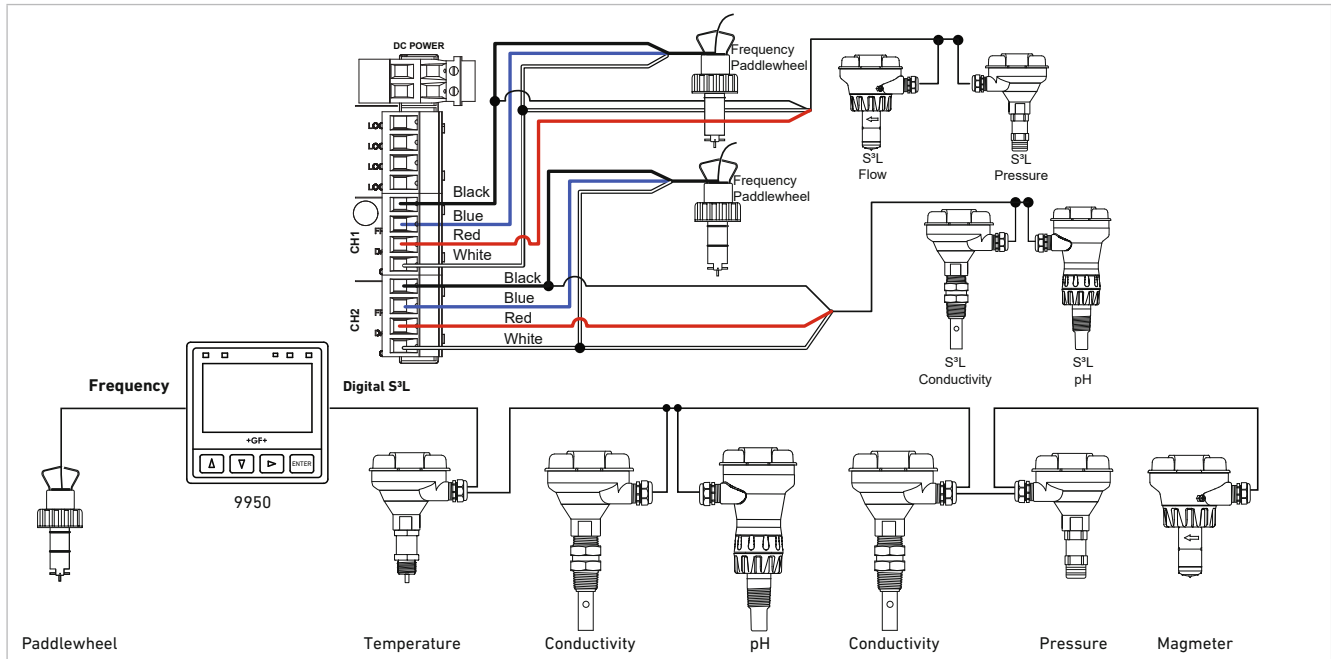

### Rear Terminal Views GF Instruments

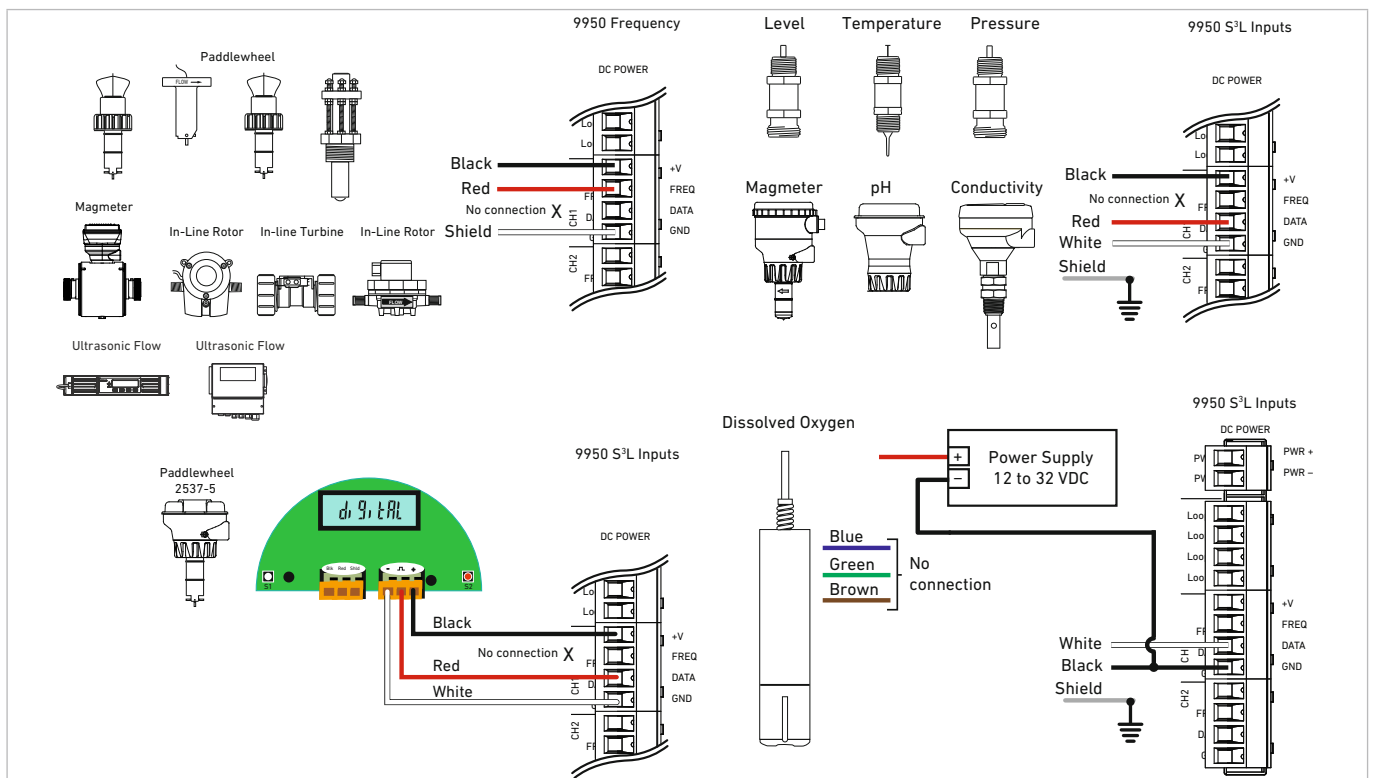

#### Important:

An external DC supply is needed for the 2610-51 Dissolved Oxygen sensor when the 9950 is AC powered. The 3-9950-2/11 with AC power will not supply power to the 2610-51 Sensor. A power supply of 12 to 24 VDC regulated is required.

## Rear Terminal Views type 9950 Transmitter

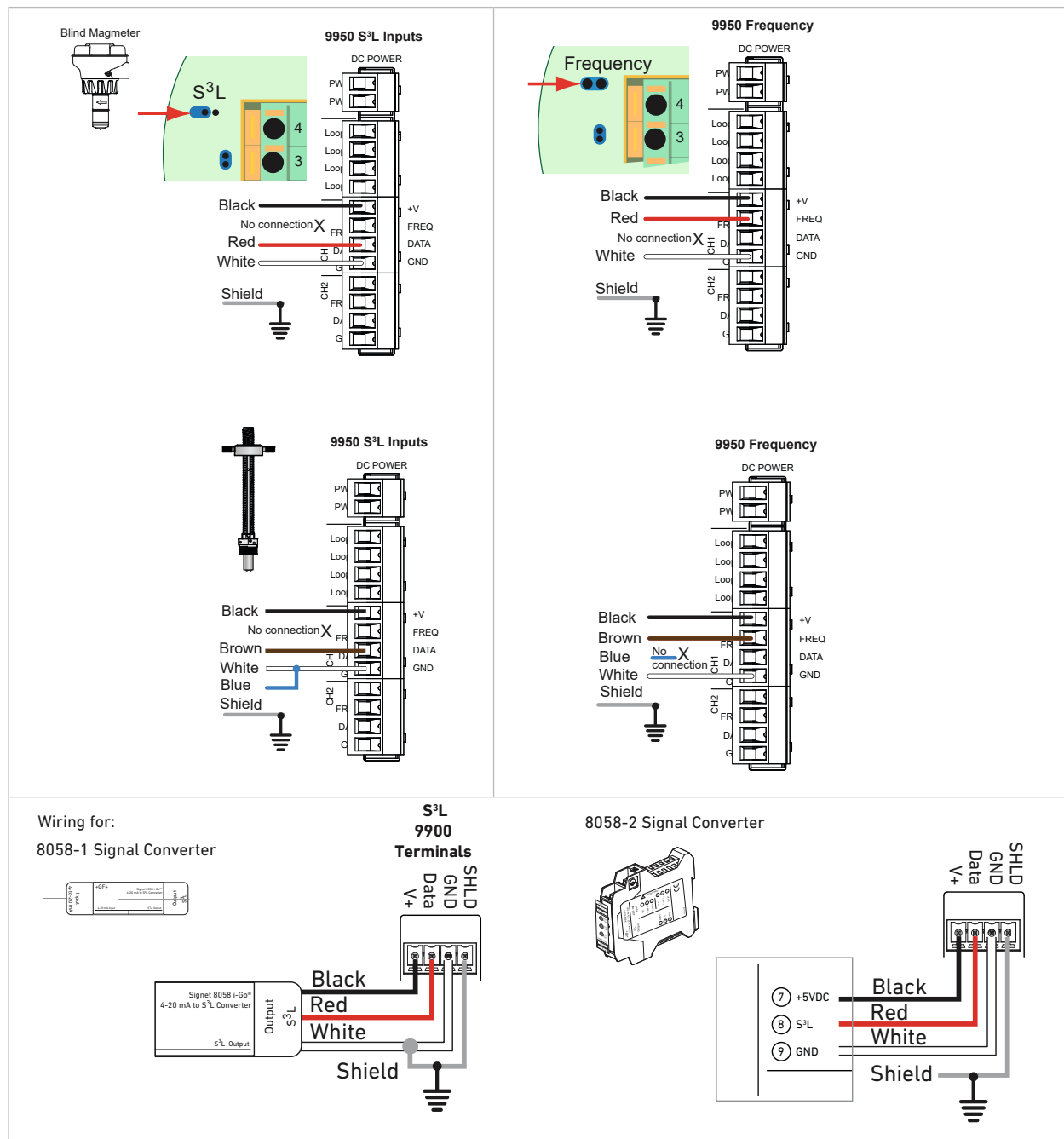

## FlowtraMag® Meter Wiring to type 9950

GF Config Tool App set to S<sup>3</sup>L

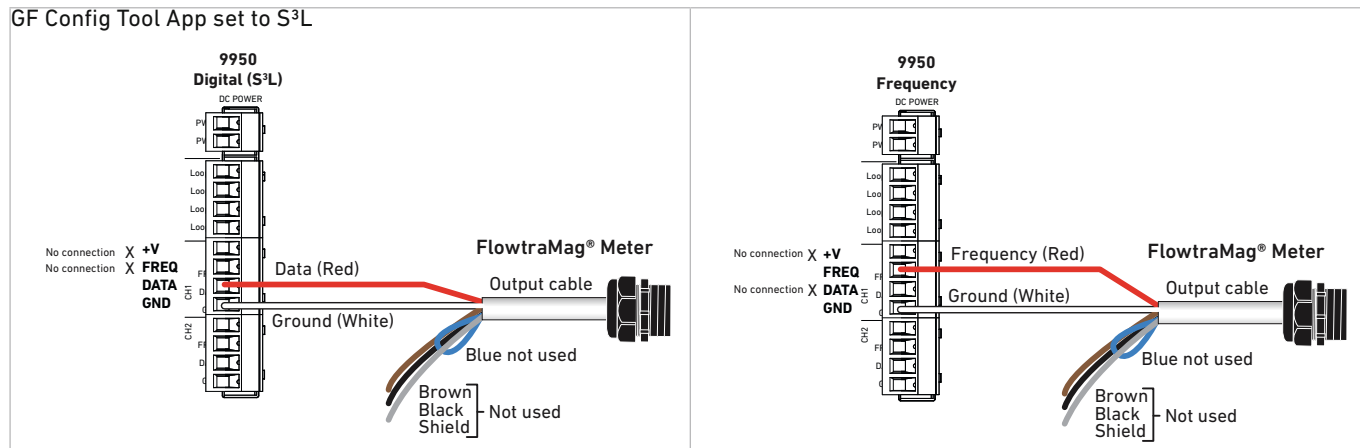

## Power Wiring

### 3-9950 DC Power

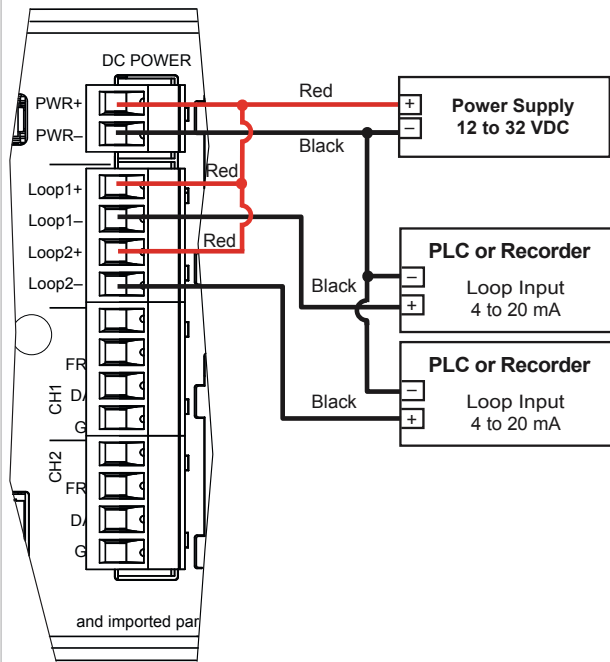

### 3-9950 AC Power

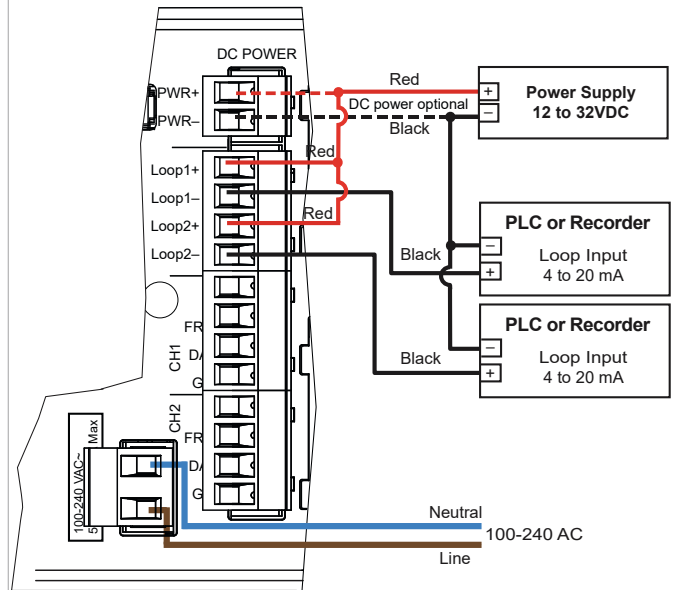

#### Important:

An external DC power supply is required for the 4 to 20 mA Loop Outputs. The 9950 does not supply power on the DC Power Terminals.

### Single Channel Conductivity Module

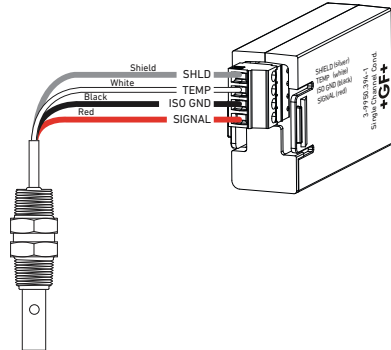

### Dual Channel Conductivity Module

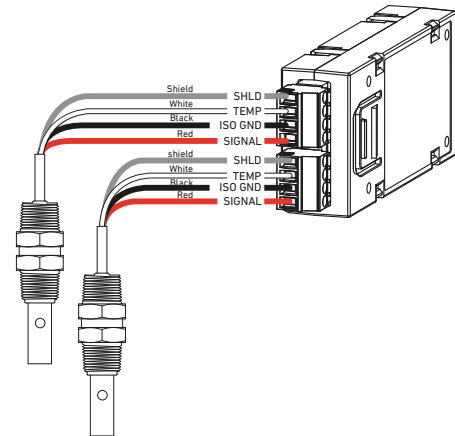

### Dual Channel 4 to 20 mA Module

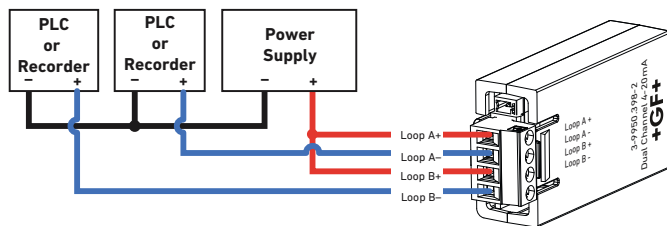

### Modbus Module

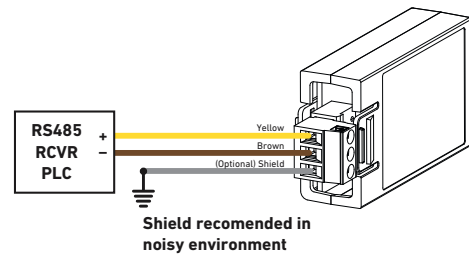

## Relay Module Wiring

3-9950.393-1

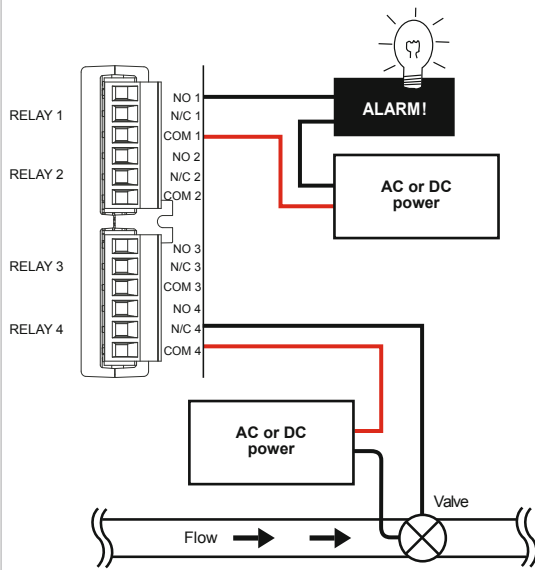

9950.393 Internal Power

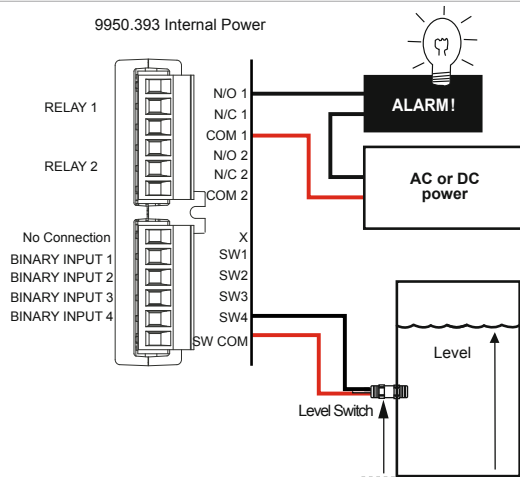

9950.393 External Power

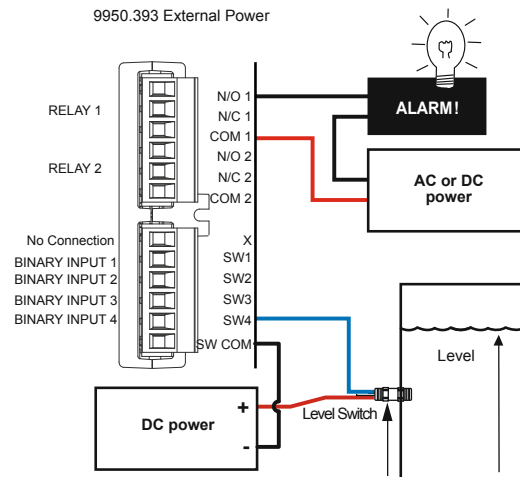

The information and technical data (altogether "Data") herein are not binding, unless explicitly confirmed in writing. The Data neither constitutes any expressed, implied or warranted characteristics, nor guaranteed properties or a guaranteed durability. All Data is subject to modification. The General Terms and Conditions of Sale of Georg Fischer Piping Systems apply.

04/2025-A 3-9950-10.099 Rev C