

Signet 2537 Paddlewheel Flowmeter



3-2537.090 Rev. 11 03/19

Operating Instructions



Description

The 2537 Paddlewheel Flowmeter Series offer low flow, low power and high resolution with various output options such as a Volumetric Pulse, Pulse Divider, Flow Switch, Digital (S³L), or 4 to 20 mA. This unit can be configured on-site directly through the built-in user interface.

- The 4 to 20 mA model provides a blind current loop output.
- The Digital (S³L) model provides a Digital (S³L) output for use with the Signet 8900 Multi-Parameter Controller or 9900 Transmitter.
- The Multi model uses a single relay (mechanical or solid state) and has three selectable operating modes:
 - Divider Mode scales the paddlewheel frequency down to accommodate low frequency input devices.
 - Total Mode outputs one pulse per a set volume of fluid.
 - Flow Switch Mode uses a single relay for Hi or Lo alarm operation.

A small LCD enables the 2537 to be programmed without any external equipment. During normal operation the display is not visible.

Table of Contents

| | |
|---|-------|
| Warranty Statement..... | 2 |
| Product Registration | 2 |
| Safety Information..... | 2 |
| Chemical Compatibility | 2 |
| Specifications..... | 3 |
| Location of Fitting | 4 |
| Sensor Mounting Position..... | 4 |
| Pipe Fittings..... | 4 |
| Dimensions..... | 5 |
| Installation..... | 5 |
| Wiring..... | 5 |
| Digital (S ³ L) Output Wiring..... | 6 |
| 4 to 20 mA Output Wiring..... | 6 |
| Flow Switch Output (On-Off)..... | 7 |
| Pulse Output | 7 |
| Dry Contact Relay Wiring..... | 7 |
| Solid State Relay Wiring | 7 |
| Operation | 8 |
| Menus | 8 |
| View Mode Function | 9 |
| Menu Details | 9 |
| Set Flow Units..... | 10 |
| Set 4 and Set 20 | 10 |
| Set K-Factor..... | 10 |
| Set Contrast | 10 |
| Averaging and Sensitivity..... | 11 |
| Set Averaging..... | 11 |
| Set Sensitivity | 11 |
| Multi Mode | 12 |
| P-Factor | 12 |
| Set Relay Operation..... | 13 |
| K-Factor | 14-15 |
| H-Dimension | 15 |
| Maintenance and Cleaning | 15 |
| Rotor Replacement Procedure | 15 |
| Ordering Information..... | 16 |



- [English](#)
- [Deutsch](#)
- [Français](#)
- [Español](#)
- [Italiano](#)
- [中文](#)



For earlier versions of this sensor, the Rev. C version of the 2537 manual is available at www.gfsignet.com, under **Resource Center**.

Select **Sensors and Instrumentation**, click **Archived Products**, select 2537, click **Instruction Manuals**.

Warranty Information

Refer to your local Georg Fischer Sales office for the most current warranty statement.

All warranty and non-warranty repairs being returned must include a fully completed Service Form and goods must be returned to your local GF Sales office or distributor. Product returned without a Service Form may not be warranty replaced or repaired.

Signet products with limited shelf-life (e.g. pH, ORP, chlorine electrodes, calibration solutions; e.g. pH buffers, turbidity standards or other solutions) are warranted out of box but not warranted against any damage, due to process or application failures (e.g. high temperature, chemical poisoning, dry-out) or mishandling (e.g. broken glass, damaged membrane, freezing and/or extreme temperatures).

Product Registration







Thank you for purchasing the Signet line of Georg Fischer measurement products.

If you would like to register your product(s), you can now register online in one of the following ways:

- Visit our website www.gfsignet.com. Under **Service and Support** click on **Product Registration Form**
- If this is a pdf manual (digital copy), [click here](#)

Safety Information

1. Depressurize and vent system prior to installation or removal.
2. Confirm chemical compatibility before use.
3. DO NOT exceed maximum temperature or pressure specs.
4. ALWAYS wear safety goggles or faceshield during installation and/or service.
5. DO NOT alter product construction.
6. If this equipment is used in a manner not specified by the manufacturer, the protection provided by the equipment may be impaired
7. **This device is not approved for use or installation in hazardous locations.**

| | |
|---|---|
|  | Caution / Warning / Danger Indicates a potential hazard. Failure to follow all warnings may lead to equipment damage, injury, or death |
|  | Personal Protective Equipment (PPE) Always utilize the most appropriate PPE during installation and service of Signet products. |
|  | Pressurized System Warning Sensor may be under pressure, take caution to vent system prior to installation or removal. Failure to do so may result in equipment damage and/or serious injury. |
|  | Hand Tighten Only Overtightening may permanently damage product threads and lead to failure of the retaining nut. |
|  | Do Not Use Tools Use of tool(s) may damage product beyond repair and potentially void product warranty. |
|  | Note / Technical Notes Highlights additional information or detailed procedure. |

Chemical Compatibility

Georg Fischer Signet products are manufactured in a variety of wetted materials to suit various liquids and chemicals.

All plastic materials including typical piping types (PVC, PVDF, PP and PE) are more or less permeable to contained media, such as water or volatile substances, including some acids. This effect is not related to porosity, but purely a matter of gas diffusion through the plastic.

If the plastic material is compatible with the medium according to the application guidelines, the permeation will not damage the plastic itself. However, if the plastic encloses other sensitive components, as is the case with GF Signet plastic paddlewheel sensors, these may be affected or damaged by the media diffusing through the plastic body and rotor.

Failures of PVDF paddlewheel sensors when used in hot nitric acid applications have been reported. PVDF is known to allow for substantial permeation of nitric acid constituents without being damaged itself. No clear guideline can be given here, since the damaging effect to the sensor is highly dependent on temperature, pressure and concentration.

Utilizing sensors in applications with aggressive substances is possible. On special request GF Signet can provide sensors with a different internal resin encapsulation (potting) that will delay the damaging effect of acids to the sensors.

For all Special Product inquiries or to place an order, please email signet-specialproduct@georgfischer.com.



WARNING!



Paddlewheel Retaining Nuts:

The retaining nuts of paddlewheel sensors are not designed for prolonged contact with aggressive substances. Strong acids, caustic substances and solvents or their vapor may lead to failure of the retaining nut, ejection of the sensor and loss of the process fluid with possibly serious consequences, such as damage to equipment and serious personal injury. Retaining nuts that may have been in contact with such substances, e.g. due to leakage or spilling, must be replaced.

Paddlewheel Maintenance:

Paddlewheel flow sensors are subject to wear and may require maintenance and replacement of mechanical parts (rotors, pin, O-rings, bearings, retainers, etc.). The frequency of recommended maintenance will vary based upon application specifications, characteristics of the measured fluid, and installation details. These can include, but are not limited to: process flowrate, occurrence of water hammer, fluid corrosiveness and abrasiveness, sensor installation relevant to other equipment.

GF Signet offers individual replacement parts and rotor replacement kits, which include replacement instructions, allowing customers to perform field maintenance and reduce application down-time. Please refer to the Paddlewheel Replacement section (page 15) or contact your local GF Sales Representative with any questions.

515, 2536, 8510, 8512, 2537 Only:

To support our customers, the GF Signet Repair Department offers services to recertify the plastic paddlewheel products to factory specification. Contact your distributor or visit www.gfsignet.com for more information.

Specifications

General

| | |
|----------------------------|--|
| Flow Rate Range | 0.1 m/s to 6 m/s (0.3 ft/s to 20 ft/s) |
| Pipe Size Range | DN15 to DN200 (½ in. to 8 in.) |
| Min. Reynolds Number | 4500 |
| Wiring Ports | ½ in. NPT threads; liquid-tight connector accepts cables 7 mm to 10 mm OD (0.275 in. to 0.394 in.) |

Materials

| | |
|--------------------|--------------|
| Case | PBT, Yellow |
| Inside Cover | Valox, Black |

Wetted Materials

-P0, -P1

| | |
|-------------------|--|
| Sensor Body | Glass Filled Polypropylene |
| O-Rings | FKM |
| Pin | Titanium |
| Rotor | PVDF, Black; optional ETFE with or without carbon fiber reinforced PTFE sleeve for rotor pin |

-T0

| | |
|-------------------|--|
| Sensor Body | PVDF, Natural |
| O-Rings | FKM |
| Pin | PVDF, Natural |
| Rotor | PVDF, Natural; optional ETFE with or without carbon fiber reinforced PTFE sleeve for rotor pin |

Performance

| | |
|-----------------------------|---|
| Input Frequency Range | 1 to 1000 Hz |
| System Response | 100 ms update rate nominal |
| Paddlewheel Frequency | 49 Hz per m/s nominal (15 Hz per ft/s nominal) |
| Linearity | ±1% of maximum range @ 25 °C (77 °F) |
| Repeatability | ±0.5% maximum range @ 25 °C (77 °F) |

Electrical

Relay Specifications

| | |
|-------------------------|------------------------------------|
| Dry Contact SPDT | 5 A @ 30 VDC, 5 A @ 250 VAC |
| Solid-State Relay | 100 mA @ 40 VDC, 70 mA @ 33 VAC |

Power Requirements

Multi:

| | |
|----------------------------------|--|
| with Dry-Contact Relay | 24 VDC nominal ±10%, regulated, 30 mA max. current |
| with Solid-State Relay | 5 to 24 VDC nominal ±10%, regulated, 30 mA max. current |
| Digital (S ³ L) | 5.0 VDC min. to 6.5 VDC max., 30 mA max. current (1.5 mA nominal) |
| 4 to 20 mA | 400 mV max. ripple voltage, 30 mA max. current |

Reverse Polarity and

| | |
|-------------------------------|----------------------|
| Short Circuit Protected | Up to 40 V, 1 hour |
| Over-Voltage Protection | > 40 VDC over 1 hour |

Output

| | |
|----------------------------|-------------------------------|
| Signal Averaging | Programmable 0 to 100 seconds |
| Sensitivity Response | Programmable 0 to 9 scale |

Pulse Divider/Total Pulse Output

| | |
|-----------------------------|-----------------|
| Pulse Divider Setting | 1.0000 to 99999 |
| Maximum pulse rate | 300 Hz |
| Maximum pulse width | 50 ms |

Flow Switch Output

| | |
|-------------------|---------------------------------|
| Relay Modes | Low, High |
| Time Delay | 0.0 to 6400.0 seconds |
| Hysteresis | Adjustable in Engineering Units |

Digital (S³L) output

| | |
|----------------------------|--|
| Type | Serial ASCII, TTL level 9600 bps |
| Maximum Cable Length | Application dependent (See 8900 manual) |

Current output (Passive 4 to 20 mA)

| | |
|------------------------------|-------------------------------|
| Loop Accuracy | ±32 µA (@ 25 °C @ 24 VDC) |
| Loop Resolution | 5 µA |
| Temp. Drift | ±1 µA per °C max. |
| Power Supply Rejection | ±1 µA per V |
| Maximum Cable Length | 305 m (1,000 ft) |
| Max. Loop Resistance | 600 Ω @ 24 VDC, 1 KΩ @ 32 VDC |

Environmental Requirements

| | |
|---------------------------|-----------------------------------|
| Enclosure Rating | NEMA 4X/IP65 |
| Storage Temperature | -10 °C to 75 °C (14 °F to 167 °F) |
| Ambient Temperature | 0 °C to 65 °C (32 °F to 150 °F) |
| Relative Humidity | 0 to 90% RH, non-condensing |
| Altitude | 2000 m (6,562 ft) |
| Pollution Degree | 2 |

Pressure/Temperature Ratings

Polypropylene Body

- 12.5 bar (180 psi) max. @ 20 °C (68 °F)
- 1.7 bar (25 psi) max. @ 85 °C (185 °F)

PVDF Body

- 14 bar (200 psi) max. @ 20 °C (68 °F)
- 1.7 bar (25 psi) max. @ 85 °C (185 °F)

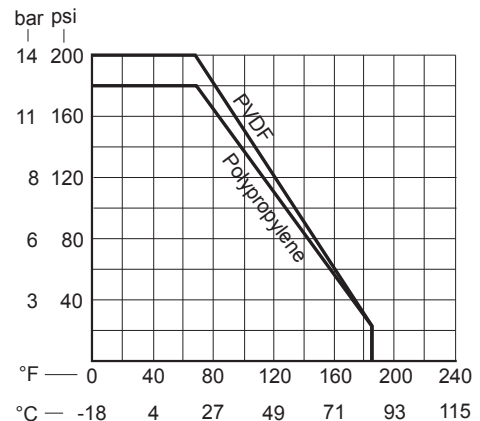

Intended Use

This product is intended for use in industrial water treatment and wastewater treatment applications where the chemical content and the fluid temperatures are consistent with the specifications listed herein.

This device is not approved for use or installation in flammable liquids.

Standards and Approvals

- CE, UL
- NSF (3-2537-xC-Px versions only)
- China RoHS (Go to www.gfsignet.com for details)
- Manufactured under ISO 9001 for Quality, ISO 14001 for Environmental Management and OHSAS 18001 for Occupational Health and Safety.

FC Declaration of Conformity according to FCC Part 15

This device complies with Part 15 of the FCC rules. Operation is subject to the following two conditions:
(1) This device may not cause harmful interference, and
(2) This device must accept any interference received, including interference that may cause undesired operation.

Location of Fitting

Recommended sensor upstream/downstream mounting requirements:

Select a location with sufficient length of straight pipe immediately upstream of the sensor.

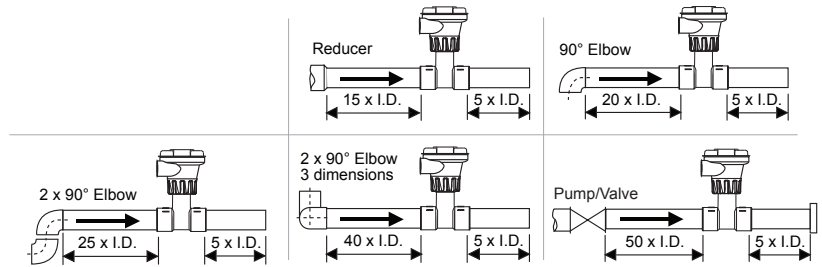

Locating the sensor in a trap or where the flow is upward helps to protect the sensor from exposure to air bubbles when the system is in operation.

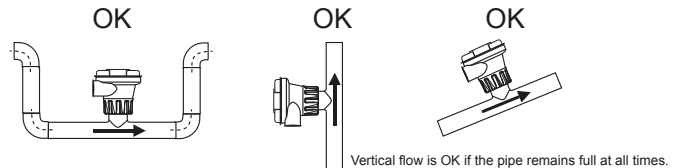

These configurations are not recommended because it is difficult to keep the pipe full.

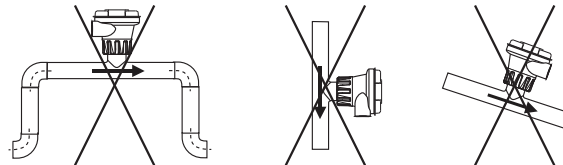

Sensor Mounting Position

Horizontal pipe runs:

Mount sensor in the upright (0°) position for best performance. Mount at a maximum of 45° when air bubbles are present (pipe must be full).

Do not mount on the bottom of the pipe when sediments are present.



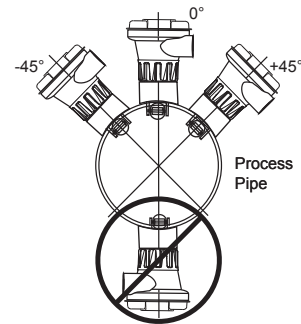

Vertical pipe runs:



Mount sensor in any orientation; however, downward flow is not recommended. Upward flow is preferred to ensure full pipe.



Pipe Fittings

Georg Fischer Signet offers a wide selection of installation fittings that control the position of the paddlewheel in relation to the dimensions of the pipe.

| Type | Description |
|--|---|
|  Plastic tees | <ul style="list-style-type: none"> 0.5 to 2 inch versions (MPVC or CPVC) 2.5 to 4 inch versions (PVC) |
|  PVC Glue-on Saddles | <ul style="list-style-type: none"> Available in 10 and 12 inch sizes only Cut 2-1/2 inch hole in pipe Weld in place using solvent cement |
|  PVC Saddles | <ul style="list-style-type: none"> 2 to 4 inch, cut 1-7/16 inch hole in pipe 6 to 8 inch, cut 2-1/8 inch hole in pipe |
|  Iron Strap-on saddles | <ul style="list-style-type: none"> 2 to 4 inch, cut 1-7/16 inch hole in pipe Over 4 inch, cut 2-1/8 inch hole in pipe Special order 14 in. to 36 in. |
|  Metric Wafer Fitting | <ul style="list-style-type: none"> For pipes DN65 to 200 mm PP or PVDF |

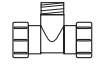
| Type | Description |
|--|---|
|  Iron, Carbon Steel, 316 SS Threaded tees | <ul style="list-style-type: none"> 0.5 to 2 in. versions Mounts on threaded pipe ends |
|  Carbon steel & stainless steel Weld-on Weldolets | <ul style="list-style-type: none"> 2 to 4 inch, cut 1-7/16 inch hole in pipe Over 4 inch, cut 2-1/8 inch hole in pipe |
|  Fiberglass tees FPT | <ul style="list-style-type: none"> 1.5 in. to 2 in. PVDF insert |
|  Metric Union Fitting | <ul style="list-style-type: none"> For pipes from DN 15 to 50 mm PP or PVDF |

Dimensions

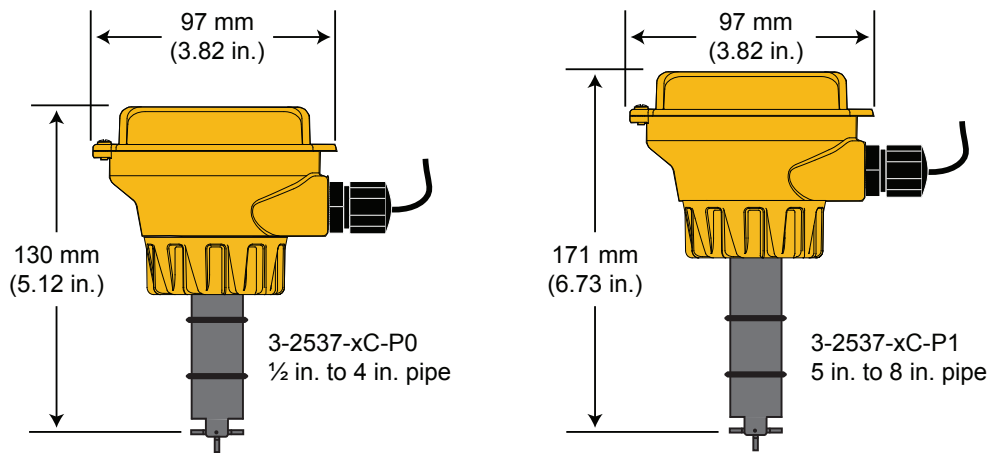

Installation

Plastic sensor installation tips

- Inspect the sensor O-rings for nicks and other damage that may compromise the seal.
- Lubricate O-rings with a non-petroleum based, viscous lubricant (grease) compatible with the system.
- Using an alternating/twisting motion, lower the sensor into the fitting, making sure the conduit ports on the yellow housing are pointing in the direction of flow.
- Engage one thread of the sensor cap then turn the sensor until the alignment tab is seated in the fitting notch.



HAND-TIGHTEN THE THREADED NUT ONTO THE INSTALLATION FITTING. DO NOT USE TOOLS!



DO NOT USE THREAD SEALANT OR LUBRICANTS ON THE FITTING THREADS OR THE SENSOR CAP.

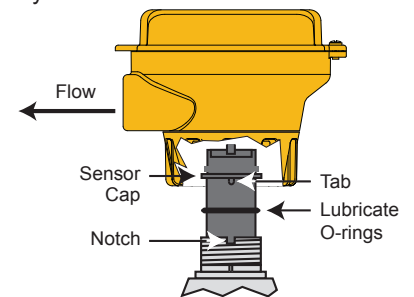

Wiring

Electrical connections to this product should be made only by qualified personnel.

To access the wiring terminals:

1. Turn yellow cap ¼ turn counterclockwise to remove.
2. Remove the two retaining screws and remove the black cover.
 - Route all cables through the conduit ports before connecting them to the terminals.
 - Wiring terminals are rated for 16 to 22 AWG conductors.
 - The cable must be 7 mm to 10 mm in diameter (0.275 in. to 0.394 in.) to seal properly in the liquid tight connector.
3. The conduit ports have ½ inch NPT threads. After routing the cables, seal the port with a liquid tight conduit connector (3-9000.392-1) or with conduit.
 - For conduit installations:
 - Thread conduit with ½ in. NPT threads directly into the conduit port.
 - For conduit with ISO threads, use the black thread adapter included with the connector kit.
 - To comply with NEC requirements, do not use any metal conduit in the installation.

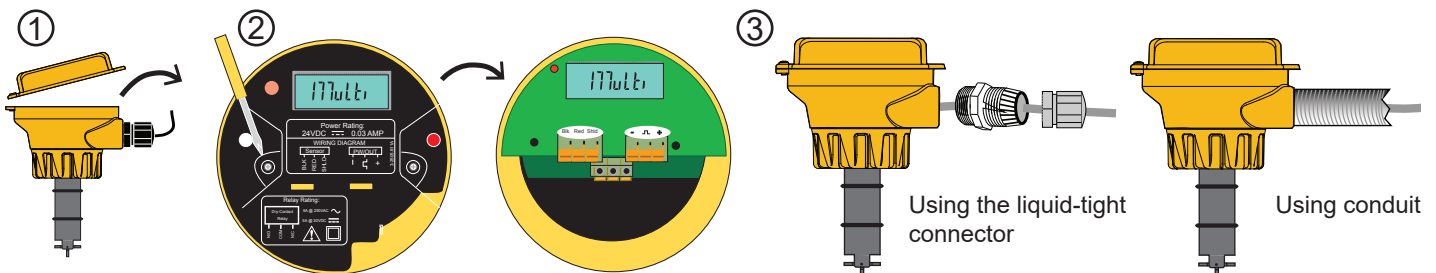

Digital (S³L) Output Wiring

The Digital (S³L) output is compatible with the 3-8900 Multi-Parameter Controller and the 3-9900 Transmitter.

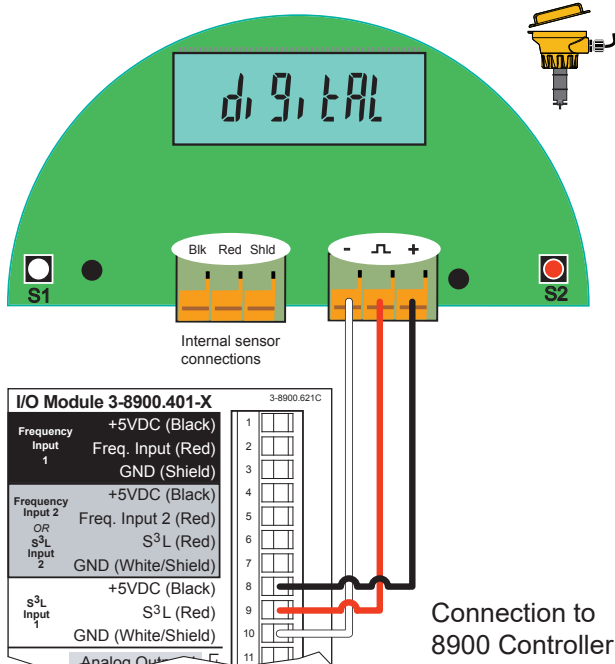
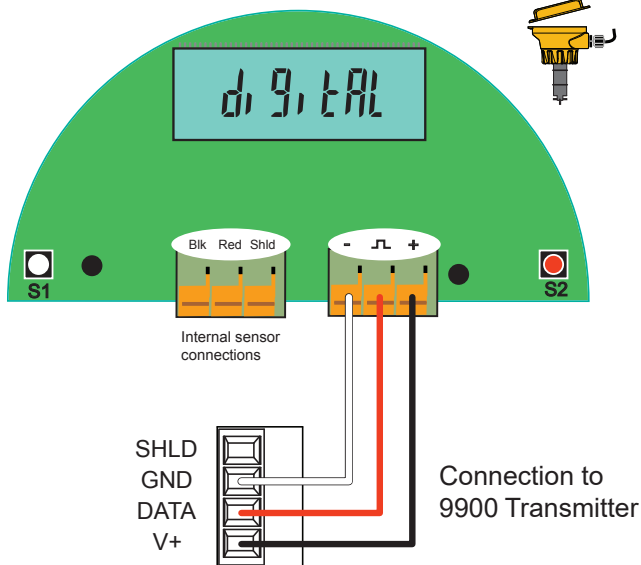
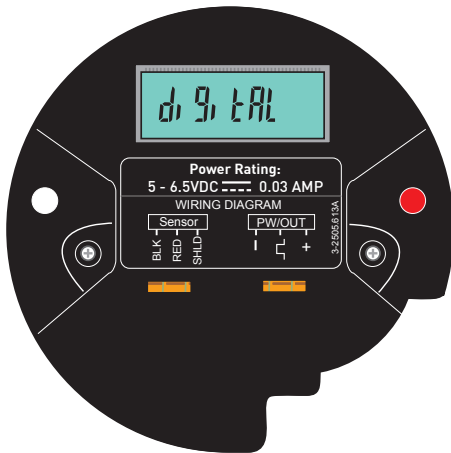

4 to 20 mA Output Wiring

- The 4 to 20 mA output can be connected to Chart Recorders, PLCs or any device that requires a 4 to 20 mA signal.
- The 4 to 20 mA model requires an external power source of 12 to 32 VDC.

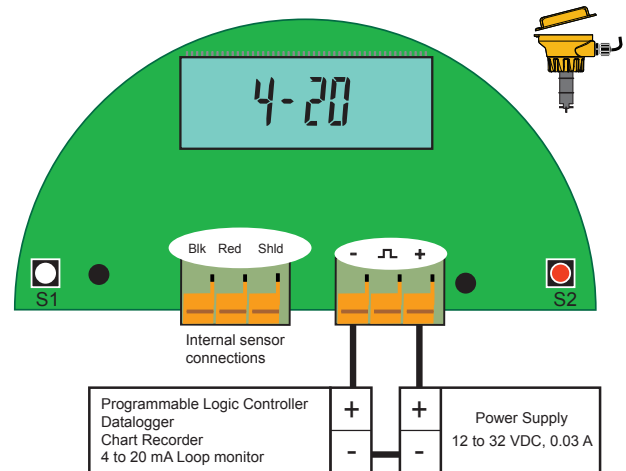

Flow Switch Output (On-Off)

- The Flow Switch mode allows a single relay that is programmable as a HIGH setpoint or LOW setpoint.
- The relay may be a dry-contact type or a solid state type:

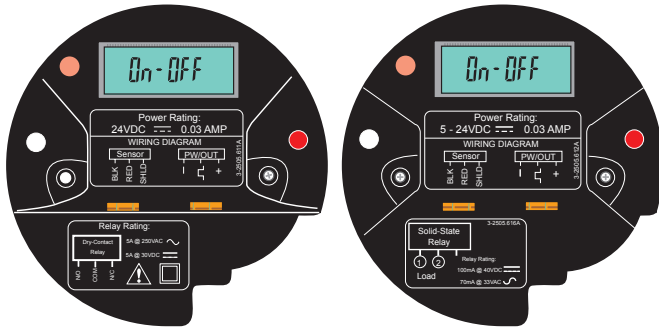

- The **Dry Contact Relay** requires an external power source of 24 VDC \pm 10%.
- The **Solid State Relay** requires an external power source of 5 to 24 VDC.

Pulse Output

- The "Multi" mode allows a single relay that is programmable as a Flow Switch, Volumetric pulse output or as a simple pulse divider output.
- The relay may be a dry-contact type or a solid state type.

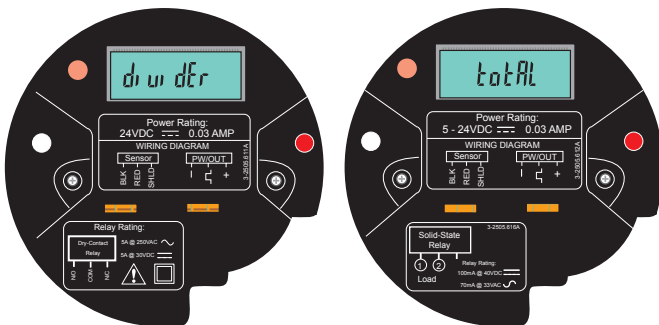

- The **Dry Contact Relay** requires an external power source of 24 VDC \pm 10%.
- The **Solid State Relay** requires an external power source of 5 to 24 VDC.
- Solid State Relay requires a pull-up resistor (10K ohm recommended). Consult your instrument/ PLC manual for wiring information.

Dry Contact Relay Wiring

- The wiring is identical for On-Off and Pulse modes.

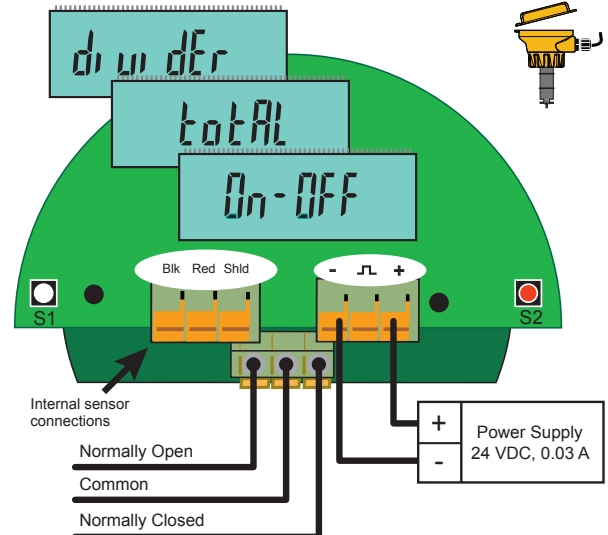

Solid State Relay Wiring

- The wiring is identical for On-Off and Pulse modes.

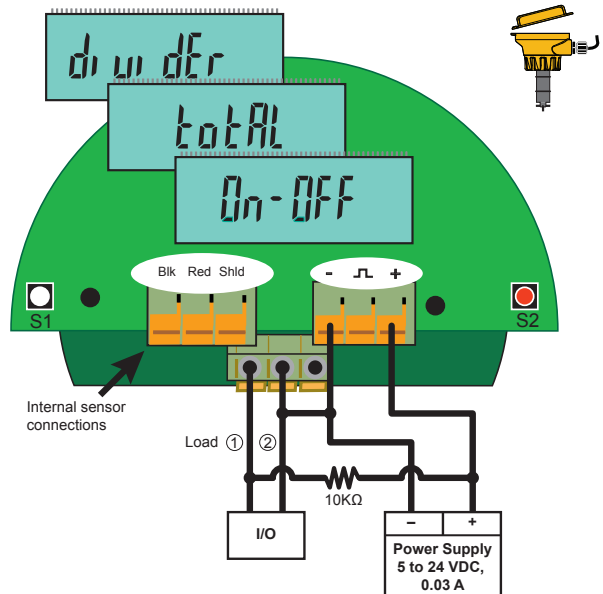

Operation

The 2537 Flowmeter is available in three different models. The programming menus vary significantly from one model to another. This chart is provided inside the yellow cover to assist in navigating the menus in the 2537.

| Mode | Action | | |
|------|----------------------|----------------------------|---------------|
| View | → Display Flow Rate | → Go to MENU | Go to VIEW |
| Menu | 1X → Next Menu | 1X → Display Current Value | Previous Mode |
| | | → Go to Edit | Previous Mode |
| Edit | 1X → Increment Value | 1X → Shift digit to right | Previous Mode |
| | | → Go to SAVE | Previous Mode |
| SAVE | 1X → Toggle | 1X → Store Change | N/A |

Menus

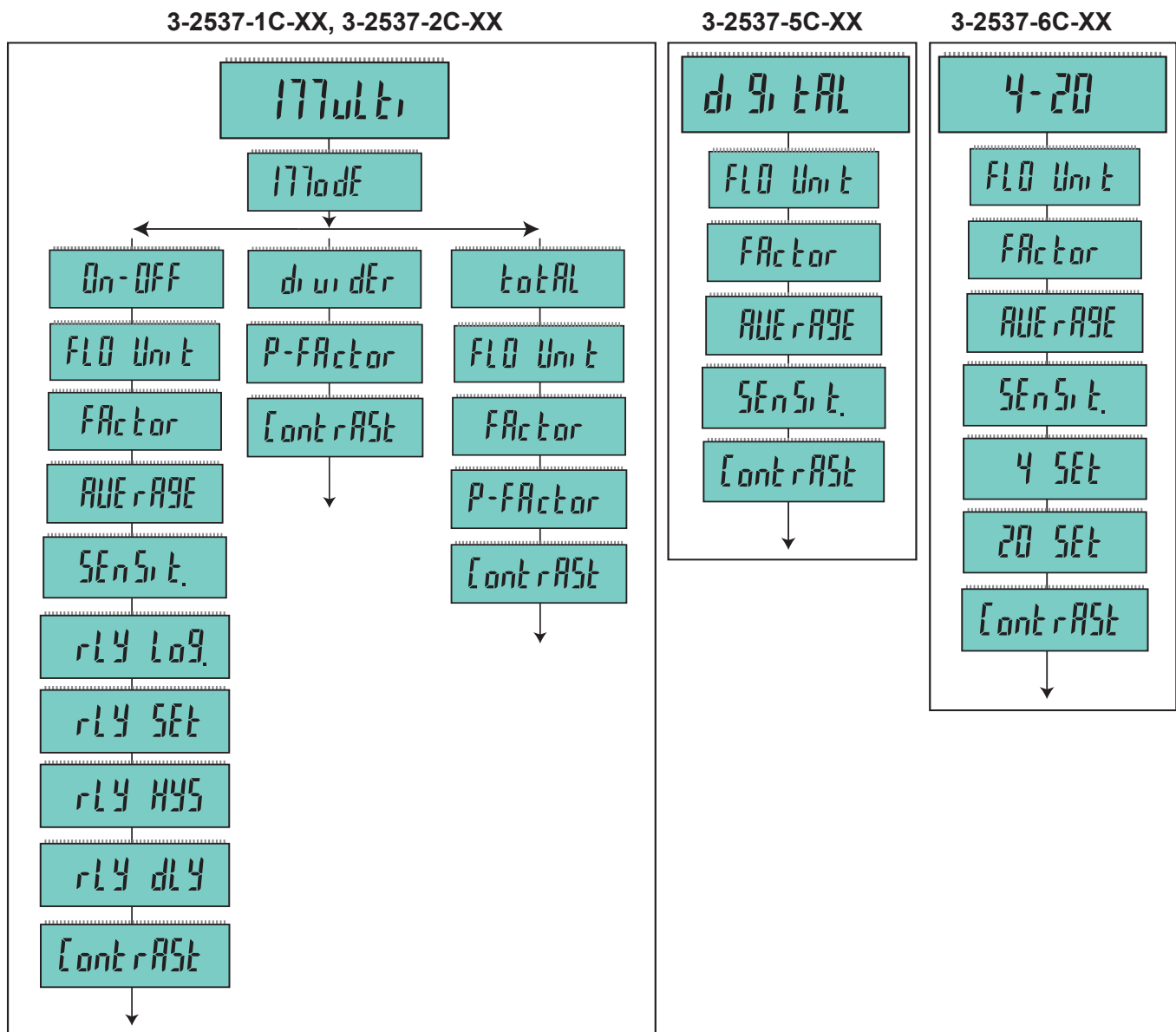

VIEW Mode Function

- All models display the model name: **Multi**, **Digital** or **4-20**.
- If the white key (S1) is held down for three seconds, the flow rate is displayed for 10 minutes before reverting back to the model name.
 - In the **Multi** Model, if the “Multi” menu item is set to “divider”, then the divided pulse output will be displayed in pulses / seconds (p/s).

Menu Details

This table shows the definition of each menu function, the setting parameters and the page where detailed instructions can be located.

| Menu Function | Definition | Setting Parameters | More Information |
|------------------|---|----------------------------|------------------|
| Flow Unit | Liters or Gallons per sec., min., hour or day | See list on page 10 | page 10 |
| K-Factor | Set PULSES per VOLUME UNIT | 0.0001 to 999999 | page 10 |
| Average | Smooths out erratic flow conditions | 0 to 100 seconds | page 11 |
| Sensitivity | Overrides Average for large rate changes | 0 to 9 | page 11 |
| Mode | Select the output mode | Total or Divider or On-OFF | page 12 |
| P-Factor | As PULSE DIVIDER, divides input freq. | 1.0000 to 99999 | page 12 |
| P-Factor | As PULSE TOTAL, multiplies K-Factor | 1.0000 to 99999 | page 12 |
| Relay Logic | Select Hi alarm or Lo alarm mode | Hi or Lo | page 13 |
| Relay Set | Set Relay Setpoint | 0.0000 to 99999 | page 13 |
| Relay Hysteresis | Rate inside Setpoint to DEENERGIZE relay | 0.0000 to 99999 | page 13 |
| Relay Delay | Time delay before relay is ENERGIZED | 0000.0 to 6400.0 | page 13 |
| 4 Set | Set flow RATE to be represented by 4 mA | 0.0000 to 99999 | page 10 |
| 20 Set | Set flow RATE to be represented by 20 mA | 0.0000 to 99999 | page 10 |
| Contrast | Adjust visibility of liquid crystal display | 1 to 3 | page 10 |

Set Flow Units

This function is available on these versions of the 2537:

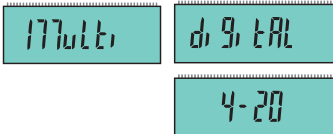

Select the volumetric units for the flow measurement:

| | |
|---|------------------------------|
| $\frac{L}{s}$ Liters/second | $\frac{g}{s}$ Gallons/second |
| $\frac{L}{m}$ Liters/minute (Factory setting) | $\frac{g}{m}$ Gallons/minute |
| $\frac{L}{h}$ Liters/hour | $\frac{g}{h}$ Gallons/hour |
| $\frac{L}{d}$ Liters/day | $\frac{g}{d}$ Gallons/day |

Example: Set the Flow Units to Gallons per minute:

- 2s FLO Unit
- 2s FLO Unit
- FLO Unit

Save the new setting:

- 2s SAVE ? n
- SAVE ? y
- Storing .

Go to next menu item Return to Normal Operation

Set 4 and Set 20

This function is available on these versions of the 2537:

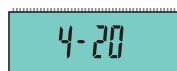

These two functions are used to span the 4 to 20 mA output signal to the required range.

The factory setting is 4 to 20 mA = 0 to 10.000

Only the 20 mA span is illustrated here.

Example: Set 20 mA = 500 GPM.

- 2s FLO Unit
- x5 20 SET
- 2s 10000
- x4 50000
- x2 50000
- 50000

Save the new setting:

- 2s SAVE ? n
- SAVE ? y
- Storing .

Go to next menu item Return to Normal Operation

Set K-Factor

A K-Factor is the number of pulses a sensor will generate for each engineering unit of fluid that passes the sensor. The factory setting is 60.0000. Locate the K-Factor in the tables on page 14 and 15.

This function is available on the above versions of the 2537:

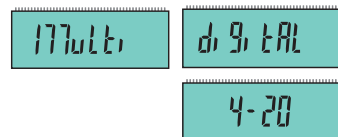

Example: Set the K-Factor to 63.5 Pulses per Gallon:

- 2s FLO Unit
- FAc tor
- 2s 06 0000
- x2 06 0000
- x3 06 3000
- 06 3000
- x5 06 3500

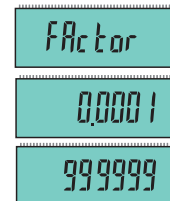

Save the new setting:

- 2s SAVE ? n
- SAVE ? y
- Storing .

Go to next menu item Return to Normal Operation

Set Contrast

This function is available on these versions of the 2537:

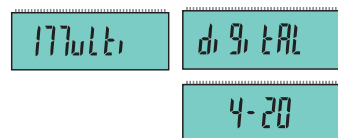

All models of the 2537 have the CONTRAST adjustment. It is always located at the end of the menu.

- 2s To access the adjustment, enter the menu and scroll until the Contrast display appears.
- x1

Repeat until :

Three levels of adjustment are available. The factory setting of 3 is the highest contrast setting.

Choose:

OR

OR

Save the new setting:

- 2s SAVE ? n
- SAVE ? y
- Storing .

Go to next menu item Return to Normal Operation

Averaging and Sensitivity Settings

- Because ideal flow conditions are often impossible to achieve, the flow rate is often erratic, which causes erratic readings in control features (e.g., relays, 4 to 20 mA loops, etc.) that are associated with the flow rate.
- The best solution to these problems is to correct any piping deficiency that causes the instability. This may involve longer straight runs upstream, reducing the pipe size to maintain a full pipe at all times, and other installation changes. In many situations, however, these measures are simply not possible.
- The 2537 meter provides two tools that are designed to "work around" these deficiencies. The Averaging and the Sensitivity features should be studied before making adjustments.

Averaging Time in Seconds (Factory set: 0 seconds)

- Set the time the meter will use as the averaging period. The range is from 0 (no average applied to input) to 100 (seconds of averaging applied to input).

Use higher averaging times to smooth the display and current output where the flow in the pipe is erratic.

Quick Response Sensitivity (Factory set: 0)

- Set the relative degree of change in the flow rate required to allow the 2537 to disable the AVERAGING and jump to a new flow rate immediately. The scale is from 0 (least sensitive, averaging is never disabled.) to 9 (a very small change in flow rate will disable the averaging).

■■■■■ No AVERAGING, no SENSITIVITY

With AVERAGING set to 0 (zero) and with SENSITIVITY set to zero, the 2537 responds to every unstable shift in the flow. The dashed red line represents the actual output of the flow sensor in unstable flow conditions.

■■■■■■ AVERAGING only

With AVERAGING set to 50 seconds and SENSITIVITY still set to zero the flow rate is stabilized, but a sharp change in flow rate is not represented for 50 seconds or longer (dotted green line).

■■■■■■ AVERAGING and SENSITIVITY

With AVERAGING at 50 seconds and SENSITIVITY set to 4 OR 5, the flow rate is stabilized, while the sudden shift in flow is reflected very quickly (solid blue line).

NOTE: The SENSITIVITY function is ineffective if the AVERAGING function is set to zero (seconds).

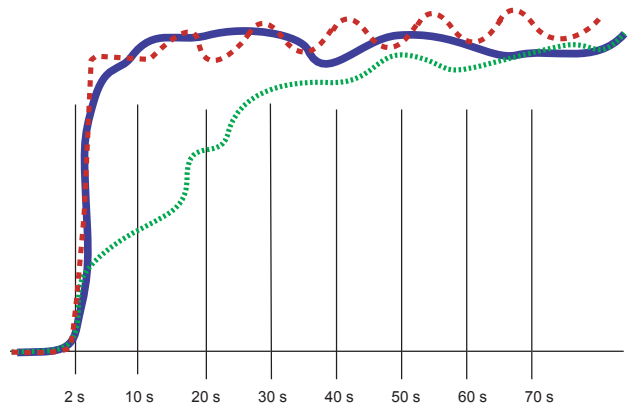

Set Averaging

This function is available on these versions of the 2537:

di g, tAL 4-20

The factory setting is 0 (zero).

AVERAGE

Minimum value 000_s

Maximum value 100_s

Example: Set the Averaging for 50 seconds.

1. 2s FLO Unit
2. x2 AVERAGE
3. 2s 000_s
4. 000_s
5. x5 050_s

Save the new setting:

1. 2s SAVE ? n
2. SAVE ? y
3. Storing .

Go to next menu item Return to Normal Operation

Set Sensitivity

This function is available on these versions of the 2537:

di g, tAL On-OFF 4-20

The factory setting is 0 (zero).

SENSIT.

Minimum value 0

Maximum value 9

Example: Set the Sensitivity to 5.

1. 2s FLO Unit
2. x3 SENSIT.
3. 2s *
4. x5 *

Save the new setting:

1. 2s SAVE ? n
2. SAVE ? y
3. Storing .

Go to next menu item Return to Normal Operation

Multi Mode

This function is available on these versions of the 2537:

177uLti

Select **DIVIDER** or **TOTAL** operation.
The factory setting is **TOTAL**.

PULSE DIVIDER Output = Input pulses ÷ P-Factor

DIVIDER allows you to set a scaling value (P-Factor) from 1.0000 to 99999.

Example: If the P-Factor is set for 2, then the 2537 will output one pulse for every 2 pulses received from the sensor. This selection enables the output frequency to be scaled down to match associated equipment capabilities.

When using the PULSE DIVIDER output, associated equipment must divide the K-Factors in this manual by the P-Factor for correct calibration.

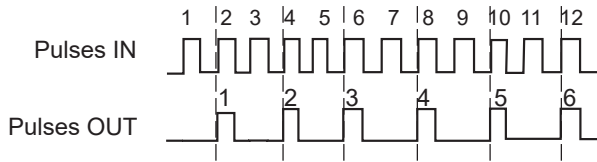

PULSE TOTAL Output = Input pulses ÷ (K-Factor × P-Factor)

TOTAL is a traditional pump pulse function. This selection will allow the entry of a K-Factor to define a volumetric unit, then set a P-Factor to define the number of volumetric units required to generate one pulse out.

Example:

Set the Total Pulse output so there is one pulse out for each 2 gallons that passes the sensor if the K-Factor is 3.0.

1. K-Factor = 3.0 (pulses in per gallon)
2. P-Factor = 2 (gallons out per pulse)

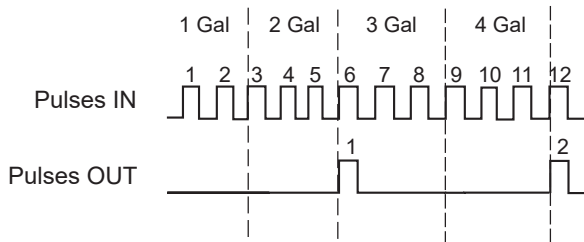

1. 177ode

2. total

3. divider

On OFF

Save the new setting:

SAVE ? n

SAVE ? y

Storing.

Go to next menu item

Return to Normal Operation

P-Factor

This function is available on the above versions of the 2537:

177uLti

divider

total

The factory setting is 1.0000

P-Factor

Minimum value

1.0000

Maximum value

99999

In PULSE DIVIDER mode the P-Factor divides:

The pulse stream from the paddlewheel sensor will be divided by the P-Factor. The resulting frequency is output through a relay.

In PULSE TOTAL mode the P-Factor multiplies:

The pulse stream from the paddlewheel sensor is divided by the K-Factor MULTIPLIED by the P-factor. The resulting frequency is output through a relay.

1. P-Factor

2. 1.0000

3. 0.0000

4. 0.0000

5. 0.0000

Save the new setting:

SAVE ? n

SAVE ? y

Storing.

Go to next menu item

Return to Normal Operation

Set Relay Operation

The On-OFF mode has one relay (SPDT or solid-state) that can be programmed as a HIGH (Hi) alarm or a LOW (Lo) alarm.



1. Select HI or LO Relay Alarm logic

A HI alarm will be activated when the flow rate rises ABOVE the setpoint.

A LO alarm will be activated when the flow rate falls BELOW the setpoint.

The factory setting is Hi(gh).

Example: Change the Relay Logic to Low:

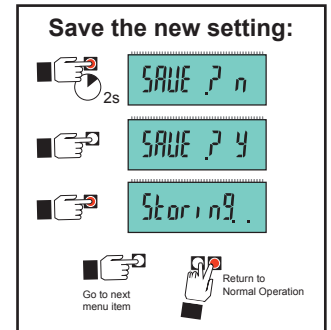
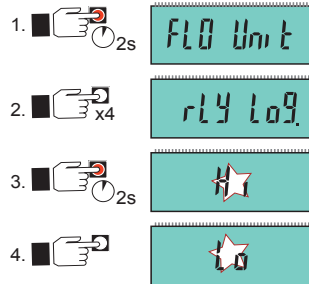

2. Program the SETPOINT.

The SETPOINT is the flow rate where the relay will be energized. The factory setting is 5.0000.

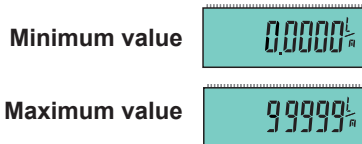

Example: Change the Setpoint to 8.0000:

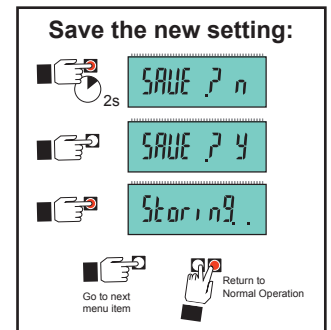
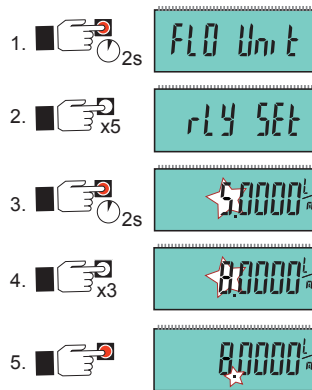

3. Program the HYSTERESIS.

Hysteresis holds a relay energized until the flow rate moves this amount past the setpoint. The factory setting is 0.5000.

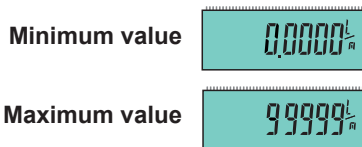

Example: Change the Hysteresis to 5.0000:

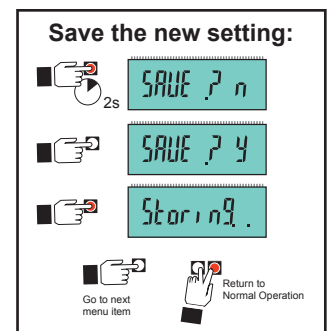
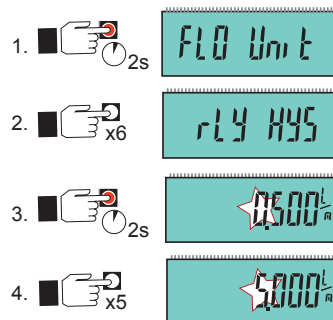

4. Program the DELAY.

When the flow rate reaches the setpoint, the 2537 will wait this long (in seconds) before triggering the alarm. The factory setting is 0000.0 seconds.

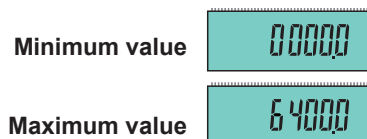

Example: Change the Delay to 10.0:

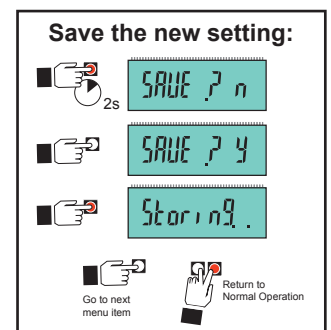
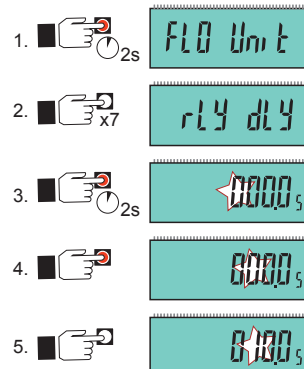

K-Factor

When using the PULSE DIVIDER mode, associated equipment must divide the K-Factors by the P-Factor.

A **K-Factor** is the number of pulses a sensor will generate for each engineering unit of fluid that passes the sensor. K-Factors for water are listed below in U.S. gallons and liters.

For example, in a 1 inch SCH 80 PVC pipe, using the MPV8T010 PVC fitting, the 2537 paddlewheel generates 335.53 pulses per gallon of water passing the rotor.

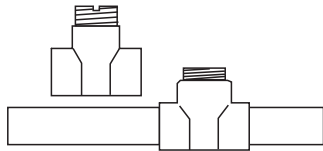

Molded Tees

| PIPE SIZE (IN.) | FITTING | 2537 SENSOR | |
|---|-------------------------------------|-------------|--------|
| | | U.S. GAL | LITERS |
| SCH 80 MOLDED TEES FOR SCH 80 PVC PIPE | | | |
| 1/2 | MPV8T005F MPV8T005 MCPV8T005F | 1027.1 | 271.37 |
| 3/4 | MPV8T007F MPV8T007 MCPV8T007F | 583.19 | 154.08 |
| 1 | MPV8T010F MPV8T010 MCPV8T010F | 335.53 | 88.65 |
| 1-1/4 | MPV8T012F MPV8T012 MCPV8T012F | 178.79 | 47.24 |
| 1-1/2 | MPV8T015F MPV8T015 MCPV8T015F | 121.42 | 32.08 |
| 2 | MPV8T020F MPV8T020 MCPV8T020F | 71.44 | 18.87 |
| 2-1/2 | PV8T025 | 42.994 | 11.359 |
| 3 | PV8T030 | 26.652 | 7.0414 |
| 4 | PV8T040 | 15.006 | 3.9645 |

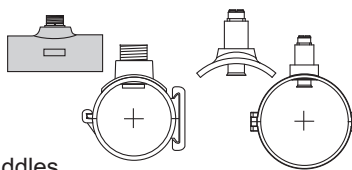

Saddles

| PIPE SIZE (IN.) | FITTING | 2537 SENSOR | |
|---|---------|-------------|--------|
| | | U.S. GAL | LITERS |
| SCH 80 PVC SADDLES FOR SCH 80 PVC PIPE | | | |
| 2 | PV8S020 | 66.739 | 17.633 |
| 2-1/2 | PV8S025 | 42.994 | 11.359 |
| 3 | PV8S030 | 26.652 | 7.0414 |
| 4 | PV8S040 | 15.006 | 3.9645 |
| 6 | PV8S060 | 8.3246 | 2.1994 |
| 8 | PV8S080 | 5.0164 | 1.3253 |
| SCH 80 PVC SADDLE ON SCH 40 PVC PIPE | | | |
| 2 | PV8S020 | 54.700 | 14.452 |
| 2-1/2 | PV8S025 | 37.159 | 9.8175 |
| 3 | PV8S030 | 23.697 | 6.2608 |
| 4 | PV8S040 | 13.456 | 3.5552 |
| 6 | PV8S060 | 7.4594 | 1.9708 |
| 8 | PV8S080 | 4.5292 | 1.1966 |

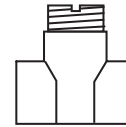

Metal Tees

| PIPE SIZE (IN.) | FITTING | 2537 SENSOR | |
|--|---------|-------------|--------|
| | | U.S. GAL | LITERS |
| CARBON STEEL TEES ON SCH 40 PIPE | | | |
| 1/2 | CS4T005 | 756.00 | 199.74 |
| 3/4 | CS4T007 | 438.69 | 115.90 |
| 1 | CS4T010 | 286.78 | 75.768 |
| 1-1/4 | CS4T012 | 121.22 | 32.026 |
| 1-1/2 | CS4T015 | 91.139 | 24.079 |
| 2 | CS4T020 | 54.468 | 14.391 |
| STAINLESS STEEL TEES ON SCH 40 PIPE | | | |
| 1/2 | CR4T005 | 734.20 | 193.98 |
| 3/4 | CR4T007 | 412.10 | 108.88 |
| 1 | CR4T010 | 252.70 | 66.764 |
| 1-1/4 | CR4T012 | 128.12 | 33.849 |
| 1-1/2 | CR4T015 | 77.320 | 20.428 |
| 2 | CR4T020 | 45.780 | 12.095 |
| GALVANIZED IRON TEES ON SCH 40 PIPE | | | |
| 1 | IR4T010 | 213.01 | 56.277 |
| 1-1/4 | IR4T012 | 127.75 | 33.751 |
| 1 1/2 | IR4T015 | 94.401 | 24.941 |
| 2 | IR4T020 | 59.420 | 15.699 |
| BRONZE TEES ON SCH 40 PIPE | | | |
| 1 | BR4T010 | 213.01 | 56.277 |
| 1-1/4 | BR4T012 | 127.75 | 33.751 |
| 1-1/2 | BR4T015 | 94.401 | 24.941 |
| 2 | BR4T020 | 59.420 | 15.699 |
| COPPER TEE ON COPPER PIPE SCH K | | | |
| 1/2 | CUKT005 | 917.84 | 242.50 |
| 3/4 | CUKT007 | 428.27 | 113.15 |
| 1 | CUKT010 | 256.43 | 67.749 |
| 1-1/4 | CUKT012 | 176.44 | 46.615 |
| 1-1/2 | CUKT015 | 115.69 | 30.565 |
| 2 | CUKT020 | 63.385 | 16.746 |
| COPPER TEE ON COPPER PIPE SCH L | | | |
| 1/2 | CUKT005 | 858.22 | 226.74 |
| 3/4 | CUKT007 | 385.74 | 101.91 |
| 1 | CUKT010 | 241.64 | 63.841 |
| 1-1/4 | CUKT012 | 170.90 | 45.152 |
| 1-1/2 | CUKT015 | 112.03 | 29.598 |
| 2 | CUKT020 | 61.74 | 16.310 |

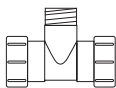

Union Tees

| PIPE SIZE | FITTING | 2537 SENSOR | |
|---|---------|-------------|--------|
| | | U.S. GAL | LITERS |
| POLYPROPYLENE TEES (DIN/ISO, BS, ANSI) | | | |
| DN15 | PPMT005 | 952.87 | 251.75 |
| DN20 | PPMT007 | 563.10 | 148.77 |
| DN25 | PPMT010 | 291.60 | 77.042 |
| DN32 | PPMT012 | 169.22 | 44.709 |
| DN40 | PPMT015 | 103.90 | 27.450 |
| DN50 | PPMT020 | 60.789 | 16.060 |
| DN65 | PPMT025 | 41.498 | 10.964 |
| DN80 | PPMT030 | 26.786 | 7.0769 |
| DN100 | PPMT040 | 17.415 | 4.6011 |
| DN125 | PPMT050 | 10.168 | 2.6864 |
| DN150 | PPMT060 | 7.3119 | 1.9318 |
| DN200 | PPMT080 | 3.9946 | 1.0554 |

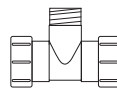

Union Tees

| PIPE SIZE | FITTING | 2537 SENSOR | |
|--|---------|-------------|--------|
| | | U.S. GAL | LITERS |
| PVDF FITTINGS (DIN/ISO AND BS AND ANSI) | | | |
| DN15 | SFMT005 | 827.26 | 218.56 |
| DN20 | SFMT007 | 489.87 | 129.42 |
| DN25 | SFMT010 | 283.55 | 74.915 |
| DN32 | SFMT012 | 158.59 | 41.899 |
| DN40 | SFMT015 | 86.980 | 22.980 |
| DN50 | SFMT020 | 50.385 | 13.312 |
| PVC FITTINGS (DIN/ISO) - EUROPE ONLY | | | |
| DN15 | PVMT005 | 972.37 | 256.90 |
| DN20 | PVMT007 | 485.69 | 128.32 |
| DN25 | PVMT010 | 297.27 | 78.540 |
| DN32 | PVMT012 | 170.25 | 44.980 |
| DN40 | PVMT015 | 103.71 | 27.400 |
| DN50 | PVMT020 | 59.500 | 15.720 |
| DN65 | PVMT025 | 34.973 | 9.2400 |
| DN80 | PVMT030 | 24.981 | 6.6000 |
| DN100 | PVMT040 | 16.275 | 4.3000 |
| DN150 | PVMT060 | 8.1756 | 2.1600 |
| DN200 | PVMT080 | 4.0878 | 1.0800 |

K-Factor

Weldolets and Brazolets



| PIPE SIZE (IN.) | FITTING | 2537 SENSOR | |
|---|---------|-------------|--------|
| | | U.S. GAL | LITERS |
| STAINLESS STEEL WELDOLETS ON SCH 40 PIPE | | | |
| 2-1/2 | CR4W025 | 37.600 | 9.9339 |
| 3 | CR4W030 | 24.340 | 6.4306 |
| 4 | CR4W040 | 13.920 | 3.6777 |
| 5 | CR4W050 | 10.860 | 2.8692 |
| 6 | CR4W060 | 7.5200 | 1.9868 |
| 8 | CR4W080 | 4.3400 | 1.1466 |
| CARBON STEEL WELDOLETS ON SCH 40 PIPE | | | |
| 2-1/2 | CS4W025 | 37.600 | 9.9339 |
| 3 | CS4W030 | 24.340 | 6.4306 |
| 4 | CS4W040 | 13.920 | 3.6777 |
| 5 | CS4W050 | 10.860 | 2.8692 |
| 6 | CS4W060 | 7.5200 | 1.9868 |
| 8 | CS4W080 | 4.3400 | 1.1466 |
| COPPER/BRONZE BRAZOLETS ON SCH 40 PIPE | | | |
| 2-1/2 | BR4B025 | 37.600 | 9.934 |
| 3 | BR4B030 | 24.340 | 6.431 |
| 4 | BR4B040 | 13.920 | 3.678 |
| 5 | BR4B050 | 10.860 | 2.869 |
| 6 | BR4B060 | 7.5200 | 1.987 |
| 8 | BR4B080 | 4.3400 | 1.147 |

Wafer Fittings



| PIPE SIZE | FITTING | 2537 SENSOR | |
|---|----------------------|-------------|--------|
| | | U.S. GAL | LITERS |
| POLYPROPYLENE WAFER FITTINGS (DIN/ISO) | | | |
| DN65 | PPMTE025 PPMTF025 | 41.498 | 10.964 |
| DN80 | PPMTE030 PPMTF030 | 26.786 | 7.0769 |
| DN100 | PPMTE040 PPMTF040 | 17.415 | 4.6011 |
| DN125 | PPMTE050 PPMTF050 | 10.168 | 2.6864 |
| DN150 | PPMTE060 PPMTF060 | 7.3119 | 1.9318 |
| DN200 | PPMTE080 PPMTF080 | 3.9946 | 1.0554 |
| PVDF WAFER FITTINGS (DIN/ISO) | | | |
| DN65 | SFMTF025 | 36.133 | 9.5465 |
| DN80 | SFMTF030 | 24.715 | 6.5297 |
| DN100 | SFMTF040 | 16.120 | 4.2589 |
| DN125 | SFMTF050 | 8.8624 | 2.3415 |
| DN150 | SFMTF060 | 6.4543 | 1.7052 |
| DN200 | SFMTF080 | 4.0720 | 1.0758 |

Iron Saddles

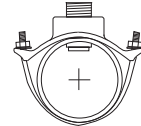

| PIPE SIZE (IN.) | FITTING | 2537 SENSOR | |
|---|---------|-------------|--------|
| | | U.S. GAL | LITERS |
| SCH 80 IRON SADDLES ON SCH 80 PIPE | | | |
| 2 | IR8S020 | 64.720 | 17.099 |
| 2-1/2 | IR8S025 | 42.480 | 11.223 |
| 3 | IR8S030 | 26.420 | 6.980 |
| 4 | IR8S040 | 14.700 | 3.884 |
| 5 | IR8S050 | 12.180 | 3.218 |
| 6 | IR8S060 | 8.4400 | 2.230 |
| 8 | IR8S080 | 4.9000 | 1.295 |
| SCH 80 IRON SADDLE ON SCH 40 PIPE | | | |
| 2 | IR8S020 | 53.640 | 14.172 |
| 2-1/2 | IR8S025 | 37.600 | 9.934 |
| 3 | IR8S030 | 23.220 | 6.135 |
| 4 | IR8S040 | 13.260 | 3.503 |
| 5 | IR8S050 | 11.040 | 2.917 |
| 6 | IR8S060 | 7.2400 | 1.913 |
| 8 | IR8S080 | 4.4000 | 1.162 |

H-Dimension

The plastic insert in Weldolet fittings MUST be removed during the welding process. When reinstalled, it is important that the insert be threaded to the proper height ("H" dimension).

| Weldolet | "H" dimension | |
|-------------|---------------|-------|
| Part number | inches | mm |
| CS4W020 | 2.38 | 60.45 |
| CS4W025 | 2.33 | 59.18 |
| CS4W030 | 2.32 | 58.92 |
| CS4W040 | 2.30 | 58.42 |
| CS4W050 | 3.09 | 78.48 |
| CS4W060 | 2.96 | 75.18 |
| CS4W080 | 2.73 | 69.34 |

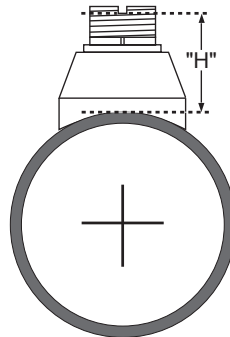

| Weldolet | "H" dimension | |
|-------------|---------------|-------|
| Part number | inches | mm |
| CR4W020 | 2.38 | 60.45 |
| CR4W025 | 2.33 | 59.18 |
| CR4W030 | 2.32 | 58.92 |
| CR4W040 | 2.30 | 58.42 |
| CR4W050 | 3.09 | 78.48 |
| CR4W060 | 2.96 | 75.18 |
| CR4W080 | 2.73 | 69.34 |

Maintenance and Cleaning

The 2537 requires very little maintenance.

- If the paddlewheel becomes fouled, it can be cleaned with mild detergents and a small brush.
- The electronics portion of the 2537 does not require maintenance or cleaning.

Rotor Replacement Procedure

1. To remove the rotor, insert a small screwdriver between the rotor and the ear of the sensor.
2. Twist the screwdriver blade to flex the ear outward enough to remove one end of the rotor and pin. DO NOT flex the ear any more than necessary! If it breaks, the sensor cannot be repaired.
3. Install the new rotor by inserting one tip of the pin into the hole, then carefully flex the opposite ear back enough to slip rotor into place.

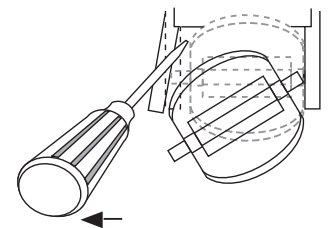

Ordering Information

| Mfr. Part No. | Code | Description |
|--|-------------|---|
| 2537 system for 0.5 in. to 4 in. pipes: | | |
| Polypropylene body, Black PVDF rotor, Titanium pin, FPM O-rings | | |
| 3-2537-1C-P0 | 159 001 291 | Pulse/Flow Switch, DCR, -P0, Integral Mount |
| 3-2537-2C-P0 | 159 001 292 | Pulse/Flow Switch, SSR, -P0, Integral Mount |
| 3-2537-5C-P0 | 159 001 295 | Digital (S ³ L), Integral Mount |
| 3-2537-6C-P0 | 159 001 296 | 4 to 20 mA, Integral Mount |

2537 system for 5 in. to 8 in. pipes:

| Mfr. Part No. | Code | Description |
|--|-------------|---|
| Polypropylene body, Black PVDF rotor, Titanium pin, FPM O-rings | | |
| 3-2537-1C-P1 | 159 001 303 | Pulse/Flow Switch, DCR, -P1, Integral Mount |
| 3-2537-2C-P1 | 159 001 304 | Pulse/Flow Switch, SSR, -P1, Integral Mount |
| 3-2537-5C-P1 | 159 001 307 | Digital (S ³ L), Integral Mount |
| 3-2537-6C-P1 | 159 001 308 | 4 to 20 mA, Integral Mount |

2537 system for 0.5 in. to 4 in. pipes:

| Mfr. Part No. | Code | Description |
|---|-------------|---|
| Natural PVDF body, Natural PVDF rotor and pin, FPM O-rings | | |
| 3-2537-1C-T0 | 159 001 315 | Pulse/Flow Switch, DCR, -T0, Integral Mount |
| 3-2537-2C-T0 | 159 001 316 | Pulse/Flow Switch, SSR, -T0, Integral Mount |
| 3-2537-5C-T0 | 159 001 319 | Digital (S ³ L), Integral Mount |
| 3-2537-6C-T0 | 159 001 320 | 4 to 20 mA, Integral Mount |

Accessories

| Mfr. Part No. | Code | Description |
|---------------|-------------|---|
| 3-2536.320-1 | 198 820 052 | Rotor, PVDF Black |
| 3-2536.320-2 | 159 000 272 | Rotor, PVDF Natural |
| 3-2536.320-3 | 159 000 273 | Rotor, ETFE |
| 3-2536.321 | 198 820 054 | Rotor and Pin, PVDF Natural |
| 3-2536.322-1 | 198 820 056 | Sleeved Rotor, PVDF Black |
| 3-2536.322-2 | 198 820 057 | Sleeved Rotor, PVDF Natural |
| 3-2536.322-3 | 198 820 058 | Sleeved Rotor, ETFE |
| M1546-1 | 198 801 182 | Rotor Pin, Titanium |
| M1546-2 | 198 801 183 | Rotor Pin, Hastelloy-C |
| M1546-3 | 198 820 014 | Rotor Pin, Tantalum |
| M1546-4 | 198 820 015 | Rotor Pin, Stainless Steel |
| P51545 | 198 820 016 | Rotor Pin, Ceramic |
| 1220-0021 | 198 801 000 | O-Ring, FKM |
| 1224-0021 | 198 820 006 | O-Ring, EPDM |
| 1228-0021 | 198 820 007 | O-Ring, FFKM |
| P31536 | 198 840 201 | Sensor Plug, Polypro |
| 3-8050.390-1 | 159 001 702 | Retaining Nut Replacement Kit, NPT, Valox® |
| 3-8050.390-3 | 159 310 116 | Retaining Nut Replacement Kit, NPT, PP |
| 3-8050.390-4 | 159 310 117 | Retaining Nut Replacement Kit, NPT, PVDF |
| 3-9000.392-1 | 159 000 839 | Liquid tight connector kit, NPT (1 piece) |
| 3-9000.392-2 | 159 000 841 | Liquid tight connector kit, PG 13.5 (1 piece) |
| 7310-1024 | 159 873 004 | 24 VDC Power Supply, 10W, 0.42 A |
| 7310-2024 | 159 873 005 | 24 VDC Power Supply, 24W, 1.0 A |
| 7310-4024 | 159 873 006 | 24 VDC Power Supply, 40W, 1.7 A |
| 7310-6024 | 159 873 007 | 24 VDC Power Supply, 60W, 2.5 A |
| 7310-7024 | 159 873 008 | 24 VDC Power Supply, 96W, 4.0 A |