

**Thank you for choosing a NIVELCO instrument**  
**We are sure that you will be satisfied throughout its use!**

# NIVOSWITCH

R-200 / R-300 SERIES  
 VIBRATING FORK LEVEL SWITCHES

USER'S MANUAL

## 1. APPLICATION

NIVOSWITCH RF□-2/3□□-□ series vibrating forks are designed for detection of level of powder, and granules. When they are used as high or low fail safe switches overflowing and emptying of silos or vessels can be prevented. The RF fork series (basic type insertion length = 125mm) with casted forks are recommended for small granules, while the RR fork series (basic type insertion length = 137mm) with welded forks are recommended for larger granules. The R-300 forks with aluminium housing are also available in dust Ex version.

## 2. TECHNICAL DATA

MODEL		R-300	R-200
Wetted parts		Stainless steel	
Process connection		According to the order code	
Housing material		Aluminium: Powder paint coated	Plastic: PBT fibre-glass reinforced, flame-retardant
Temperature ranges	Medium	-40 °C to +130 °C	
	Ambient	PP flange: -20 °C to +90 °C -40 °C to +70 °C	
Maximum pressure		Max. 4 MPa (40 bar) (with PP flange 6 bar) See 2.4 Derating Diagrams	
Insertion length		125 to 3000 mm	
Minimum medium density		≥ 0.01 kg/dm <sup>3</sup>	
Response time	Getting immersed	≤ 0.5 sec	
	Getting free	≤ 1 sec at high density setting (≥ 0.5 kg/dm <sup>3</sup> ) ≤ 3 sec at low density setting (< 0.5 kg/dm <sup>3</sup> )	
Operation mode indicator		Bi-colour LED	
Operation mode selection		Switch for selection of HIGH or LOW fail safe mode	
Density adjustment		Switch for selection of HIGH or LOW Density	
Output		1 or 2 SPDT relays Relay 1: 250 V AC, 8 A, AC 1      Relay 2: 250 V AC, 6A, AC 1	
Electrical connections		2 pcs. M20x1.5 cable glands with Ex ta IIIC protection type or for normal types M20x1.5 plastic glands for cable Ø 6 to 12 mm, 2 pcs. plug-in type terminal blocks for 0.25 to 1.5 mm <sup>2</sup> wire cross section internal thread for 2x 1/2" NPT cable protective pipe	
Supply voltage		Normal type: 20...255 V AC/DC Ex type: 20...250 V AC (50/60Hz) or 20...50 V DC	
Consumption		AC: 1.2 ... 17 VA ;      DC: < 3 W	
Electrical protection		Class I.	
Mark of explosion protection		⊕ II 1/2 D Ex ta/tb IIIC T140 °C Da/Db      -	
Ingress protection		IP 67 (NEMA 6)	
Mass		1.3 kg + 1.2 kg/m	0.95 kg + 1.2 kg/m



### 2.1 ACCESSORIES

- User's Manual
- Declaration of Conformity
- Warranty Card
- Sealing 2 mm thick made of KLINGER OILIT (for 1" BSP process connection only)
- Plug-in type, 3-pole terminal block (2 pcs for standard and 3 pcs for models with 2 relays)
- Cable gland M 20 x 1.5 (2 pcs)

### 2.2 ORDER CODE

NIVOSWITCH R □ □ - □ □ □ - □ \*

TYPE	CODE	CONNECTION	CODE	HOUSING	CODE	INSERTION LENGTH	CODE	OUTPUT / EX	CODE	
Casted fork	F	1" BSP	M	Casted alum.	3	125 / 137 mm	01	1 relay SPDT	0	
Welded fork	R	1 1/2" BSP	H	Plastic	2	200 / 175 mm	02	2 relays SPDT	A	
		1" NPT	P			0.3 ... 3 m	03...30	1 relay SPDT / Dust Ex ta/tb IIIC	B	
		1 1/2" NPT	N							
		DN50, PN16 PP DIN	F							
		DN50, PN40 1.4571 DIN	G							
		2" ANSI RF150 PP	A							
		2" ANSI RF600 1.4571	B							
		JIS 10K 50A PP	J							
		JIS 40K 50A 1.4571	K							

\*The order code of an Ex version should end in 'Ex'

### 2.3 DIMENSIONS

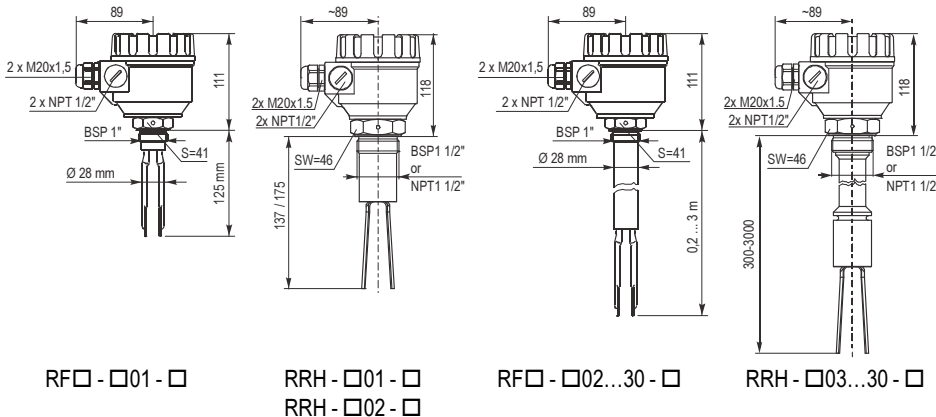

### 2.4 PRESSURE VS. TEMPERATURE DIAGRAMS

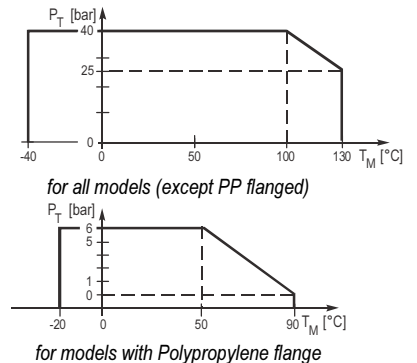

### 3. INSTALLATION

Prevent the unit from being damaged!

Before installation it is advised to try the operation of the level switch in a small sample of material in order to set the proper density.

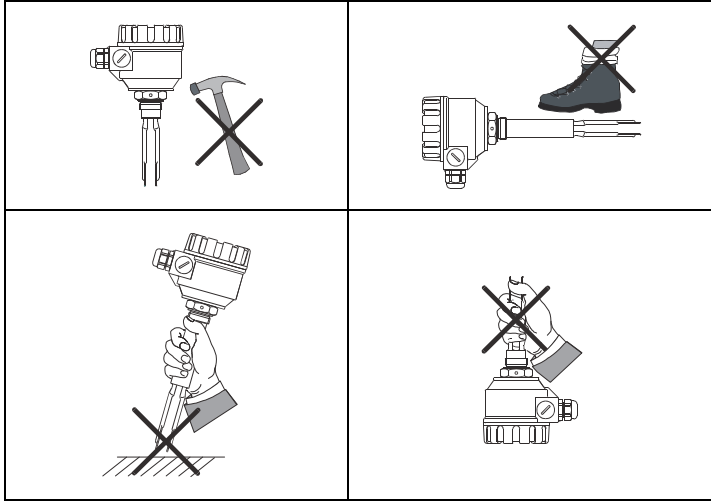

**Positioning:** the plane of the fork-tines is perpendicular to the marked plane of the hexagonal neck.

If directional positioning of the fork-tines is needed (side mounting), use the TEFLON (PTFE) tape to seal the thread and position the fork-tines to the desired direction. In this case vertical positioning of the fork-tines is suggested.

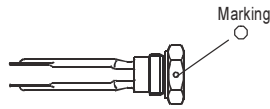

**Do not use housing to screw the unit into the process connection. Do it by means of the SW = 41/46 mm hexagonal neck.**

After screwing the device tight, the housing can be rotated by hand (max. 300°), to adjust cable glands to the required position.

The recommended mounting position for detecting light, free flowing solids is vertical (top) mounting. Side mounting is recommended only in case the fork-tines are easily freed from the process medium. In case of side mounting, NIVOSWITCH must be mounted with the fork-tines standing vertically. To determine optimal location of installation, possible caving or arching of the material in the tank should also be taken into consideration.

The fork should be protected against falling materials. This is to be done so that material could not clog between the fork and the protection plate.

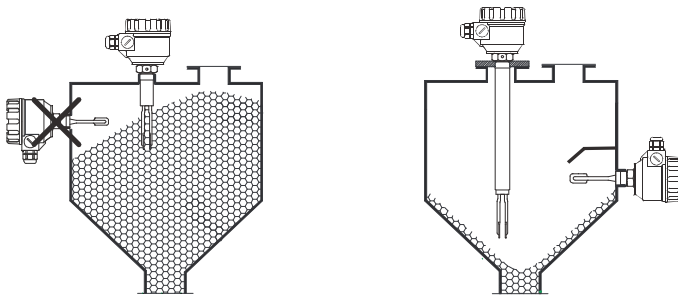

Recommended and false installations

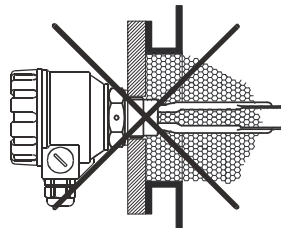
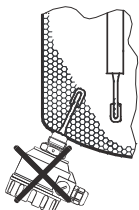

### 4. ELECTRICAL CONNECTIONS

Use 6 ... 12 mm diameter cables with 0.25 ... 1.5 mm<sup>2</sup> wire cross section and tighten cable glands as well as housing cover after installation, to ensure IP 67 sealing.

Use the external or internal grounding screw terminal for grounding the unit. Common cables must not be used for AC and DC voltage, as well as for low and mains voltage.

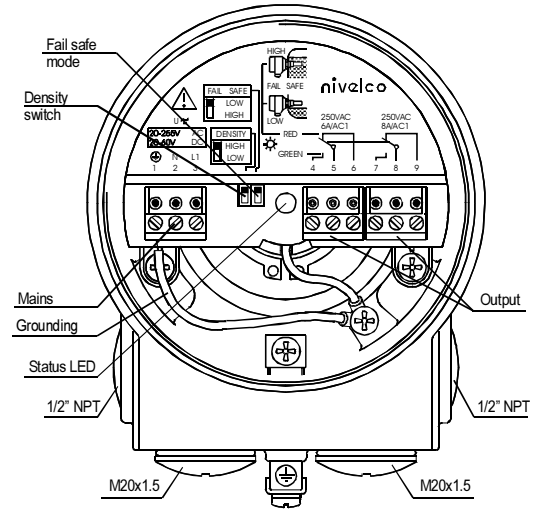

### ADJUSTMENT

Power supply	Fork	Switch pos.	Operation mode		Output
			Fail safe	Status LED	
Yes	Immersed	■	HIGH	RED	De-energised
		□	LOW	GREEN	Energised
	Free	■	HIGH	GREEN	Energised
		□	LOW	RED	De-energised
No	Free or immersed		HIGH or LOW	NOT LIT	De-energised

Operation mode display is visible even after closing the lid.

After connection and adjustment the sealings should be checked and the lid closed carefully.

### 5. MAINTENANCE

The NIVOSWITCH vibrating forks do not require maintenance on a regular basis. In some instances, however, the vibrating section may need to be cleaned from deposited material. This must be carried out carefully.

### 6. STORAGE CONDITIONS

Ambient temperature: -25 to +60 °C

Relative humidity: max. 98%

### 7. WARRANTY

NIVELCO provides warranty of 3 (three) years in compliance with details described in the Warranty Card.

rfm3010a0600h\_08  
April 2016