

Thank you for choosing a NIVELCO instrument.
We are sure that you will be satisfied throughout its use!

1. APPLICATION

The NIVOPRESS N submersible hydrostatic level transmitters are applicable for the continuous level measurement of clean or chemically faintly contaminated liquids in wells, open reservoirs or tanks. The NC type is recommended for level detection of polluted water. The NIVOPRESS is easy to install into already existing tanks and in deep drilled wells and is especially recommended for controlling submersible pumps. The use of the supplemental accessories is recommended. Using the NAW-104 sewage adapter direct contact between the sewage and the diaphragm of the built-in pressure sensor can be avoided. 2-wire types are available with built-in 4-wire Pt100 temperature sensor or separate 2-wire temperature transmitter. 2-wire types (except NCO-2□□□□) have HART® communication interface. The NOK-5□□□□ Ex types can be used in explosion hazardous environment.

2. TECHNICAL DATA

| SUBMERSIBLE PROBE | 2-WIRE | | | | 3-WIRE |
|---------------------------------------------------------------------------------|----------------------------------------------------------------------------------------------------------------------------------|----------------------------------|------------------------------------------------------------------------------------|------------------------------|----------------------------------------------------------------------------------------|
| | NP, NF, NZ, NR | NC, NT | NK, NN, ND, NH | NB, NG | NCH |
| Measurement range | 0 – 200 m (0 – 656 ft) water head | 0 – 20 m (0 – 65 ft) water head | 0 – 200 m (0 – 656 ft) water head | | |
| Overload allowed (as a function of range) | As per order code | | | | |
| Output | 4 – 20 mA + HART® | 4 – 20 mA | 4 – 20 mA + HART® | 4 – 20 mA + HART® | |
| Power supply | 12 – 30 V DC | | | | 18 – 30 V DC / 6 mA |
| Load (U _i = power supply; U _{min} = min. power supply 12 V) | $R \geq \frac{U_i - U_{min}}{0,02 A}$ | | | | ≥ 5 kohm |
| Built-in temperature sensor | HART® secondary value, accuracy: ±3 °C (±5.4°F) | – | HART® secondary value, accuracy: ±3 °C (±5.4°F) | | – |
| Linearity error (level transmitter) | ±0.25% | | ±0.45% (≤ 20 m w.h.) ±0.25% (> 20 m w.h.) | | ±0.25% |
| Temperature error | ≤ ±0.1% / 10 K | | | | ≤ ±0.2% / 10 K |
| Operating temperature* | -30 °C ... +60 °C (-22 °F ... +140 °F) | | | | |
| Process connection | NAA-209 cable mounting wedge clamp, threaded types with 3/4" BSP thread | | | | |
| Ingress protection | IP68 | | | | |
| Electrical protection | Class III | | | | |
| Electrical connection | Shielded cable with breathing capillary Ø7 mm (Ø0.275 inch) | | | | |
| Wire cross section | 0.34 mm² (AWG 22) | | | | |
| Cable length | 0 – 300 m (0 – 985 ft) as per order code; (Ex ia IIC: max. 100 m [328 ft]) | | | | |
| Dimensions | NP, NF: Ø22 x 173 mm (NP, NF: Ø0.87 x 6.8 inch) NZ, NR: Ø38 x 174 mm (NZ, NR: Ø1.5 x 6.85 inch) | Ø40 x 146 mm (Ø1.55 x 5.75 inch) | NK, NN: Ø22 x 173 mm (Ø0.87 x 6.8 inch) ND, NH: Ø38 x 174 mm (Ø1.5 x 6.85 inch) | Ø24 x 212 mm (Ø1 x 8.3 inch) | NPH: Ø22 x 173 mm (NPH: Ø0.87 x 6.8 inch) NZH: Ø38 x 174 mm (NZH: Ø1.5 x 6.85 inch) |
| Mass | NP, NF: probe: 0.2 kg (0.44 lb) NZ, NR: probe: 0.3 kg (0.66 lb) | probe: 0.4 kg (0.88 lb) | probe: 0.2 kg (0.44 lb) | | |
| Additional temperature transmitter NCO types | Output: 4 – 20 mA; Power supply: 14 – 30 V DC; Temperature range: 0 °C ... +60 °C (32 °F ... +140 °F); Accuracy: ±3 °C (±5.4 °F) | | | | – |
| Additional temperature transmitter NCP types | Pt100 B sensor, 2-wires | | | | – |
| Material of wetted parts | Sensor | 1.4404 | Al ₂ O ₃ ceramic | | 1.4404 |
| | Housing | 1.4571 | | POM-C | 1.4571 |
| | Cable coating | Polyurethane / FEP | | | |
| | Sealing | Viton® (FKM) | | | |
| | Protecting cap | 1.4571 | – | 1.4571 | POM-C |

*special order max. +75 °C

SPECIAL DATA FOR EX CERTIFIED MODELS

| TYPE | N□□-5□□□□ |
|-------------------------|---------------------------------------------------------------------------------------------------------------------------------------------------------------------------------------------------------------------------------------------------------------------|
| Power supply | 14 – 30 V DC |
| Ex marking | Up to 100 m (328 ft) cable length: between 100 m (328 ft) and 300 m (985 ft) cable length: |
| Temperature range | -30 °C ... +60 °C (-22 °F ... +140 °F) |
| Intrinsically safe data | U _i = 30 V, I _i = 100 mA, P _i = 0.8 W for IIC gas group: C _i ≤ 52 nF, L _i ≤ 1.4 mH (calculated with 100 m [328 ft] integrated cable), for IIB gas group: C _i ≤ 132 nF, L _i ≤ 1.6 mH |

ACCESSORIES

| CABLE TERMINAL BOX | NAA-101 |
|-------------------------------------------------|----------------------------------------------------------------------|
| Dimensions | 93 x 93 x 55 mm (3.66 x 3.66 x 2.16 inch) |
| Ingress protection | IP65 |
| Operating temperature | -40 °C ... +70 °C (-40 °F ... +158 °F) |
| Material | Polystyrol |
| Cable gland | M20 x 1.5 (cable Ø5 – Ø10 mm [Ø0.2 – Ø0.4 inch]) |
| Electrical connection | Terminal block for cable with max. cross section of 2.5 mm² (AWG 13) |
| CABLE TERMINAL BOX WITH OVERVOLTAGE PROTECTION* | NAA-102 |
| Data | See: NAA-101 |
| Electrical data | See: OVP |
| CABLE MOUNTING WEDGE CLAMP | NAA-209 |
| Max. mech. load | 300 m (985 ft) cable |
| Operating temperature | -20 °C ... +60 °C (-4 °F ... +140 °F) |
| OVERVOLTAGE PROTECTION | OVP 22 / 33* |
| Mounting | outdoor |
| Dimensions | 72 x 42 x 19 mm (2.8 x 1.65 x 0.75 inch) |
| Ingress protection | IP54 |
| Breakdown voltage | 33 V |
| Absorbed energy | 600 W / 1 ms |
| Internal resistance | 13 Ω |
| Leakage current | ≤ 10 µA |
| OVERVOLTAGE PROTECTION | OVP 32 / 33* |
| Mounting | EN 60715 - 35 mm (1 1/4 inch) rail |
| Dimensions | 62 x 65 x 18 mm (2.44 x 2.56 x 0.7 inch) |
| Ingress protection | IP20 |

*only for 2-wire 4 – 20 mA equipments!

NIVOPRESS

HYDROSTATIC LEVEL TRANSMITTER



USER'S MANUAL



NIVELCO

Manufacturer:

NIVELCO Process Control Co.

H-1043 Budapest, Dugonics u. 11.

Phone: (36-1) 889-0100 ■ Fax: (36-1) 889-0200

E-mail: sales@nivelco.com ■ www.nivelco.com



2.1 ACCESSORIES

- User's Manual
- Warranty Card
- Declaration of Conformity

2.2 ORDER CODE (NOT ALL COMBINATIONS POSSIBLE!)

NIVOPRESS N - -

| SENSOR / CABLE MATERIAL / HOUSING / PROCESS CONN. | CODE | OUTPUT | CODE | VERSION | CODE | MEASURING RANGE * | CODE | CODE | CABLE LENGTH | | | CODE |
|-----------------------------------------------------------------|------|----------------------------------------------------|------|-----------------|------------------|-------------------|-----------------|------|--------------|-------------|-----|------|
| Ceramic (capacitive) / PUR / 1.4571 | C | 2-wire 4 – 20 mA +HART® | K | Normal NC | 2 | 1 m water head | 1 | 0 | 0 m | Up to 100 m | 0 m | 0 |
| Ceramic (capacitive) / FEP / 1.4571 | T | 3-wire 0 – 10 V DC | H | Normal | 4 | 2 m water head | 2 | 1 | 10 m | | 1 m | 1 |
| Stainless steel (piezoresistive) / PUR / 1.4571 | P | 4 – 20 mA, level + HART® and 4 – 20 mA temperature | D | Ex | 5 | 5 m water head | 3 | : | : | | : | : |
| Stainless steel (piezoresistive) / FEP / 1.4571 | F | | | | | 10 m water head | 4 | 9 | 90 m | 9 m | 9 | |
| Stainless steel (piezoresistive) / PUR / 1.4571 / 3/4" threaded | Z | 4 – 20 mA +HART® and Pt100B | P | | | | 20 m water head | 5 | A | 100 m | 0 m | 0 |
| Stainless steel (piezoresistive) / FEP / 1.4571 / 3/4" threaded | R | | | 50 m water head | 6 | B | 200 m | 10 m | 1 | | | |
| Ceramic (piezoresistive) / PUR / 1.4571 | K | | | | 100 m water head | 7 | | | | : | : | |
| Ceramic (piezoresistive) / FEP / 1.4571 | N | | | | 200 m water head | 8 | | | | 90 m | 9 | |
| Ceramic (piezoresistive) / PUR / 1.4571 / 3/4" threaded | D | | | | | | | | | | | |
| Ceramic (piezoresistive) / FEP / 1.4571 / 3/4" threaded | H | | | | | | | | | | | |
| Ceramic (piezoresistive) / PUR / POM | B | | | | | | | | | | | |
| Ceramic (piezoresistive) / FEP / POM | G | | | | | | | | | | | |

*can be set within the range on special request

ACCESSORIES

| | | | |
|------------------------------|---------|------------------------------|------------------------------|
| Cable terminal box | NAA-101 | Sewage adapter | NAW-104 |
| Cable terminal box with OVP | NAA-102 | Overvoltage protection units | OVP 22 / 33 (outdoor) |
| Cable holding sliding sleeve | NAA-105 | | OVP 32 / 33 (rail mountable) |
| Cable mounting wedge clamp | NAA-209 | | |

2.3 DIMENSIONS

| NIVOPRESS NP PROBE | NIVOPRESS NC PROBE | NIVOPRESS NZ PROBE | NIVOPRESS NB PROBE | CABLE HOLDING WEDGE CLAMP NAA-209 |
|------------------------------------------------------------------------|--------------------|--------------------------------------|-----------------------------------------|-----------------------------------|
| | | | | |
| CABLE TERMINAL BOX NAA-101 and NAA-102 | | CABLE HOLDING SLIDING SLEEVE NAA-105 | | SEWAGE ADAPTER NAW-104 |
| <p>NAA-102 is featuring an OVP 22 / 33 overvoltage protection unit</p> | | | | |
| OVP 22 / 33 OVERVOLTAGE PROTECTION UNIT | | | OVP 32 / 33 OVERVOLTAGE PROTECTION UNIT | |
| | | | | |

3. INSTALLATION

For fastening the cable use NAA-209 cable mounting wedge clamp that provides a solution for hanging the cable without slipping and risk of rupture.

For the NP and NK types the NAW-104 sewage adapter can be snapped in the place of the sensor protecting cap.

For the NZ and ND types the NAZ-103 threaded sewage adapter can be used.

STEPS OF INSTALLATION

- The cable of the level transmitter should not be twisted. In case of NZ / NR types with threaded connection, make sure that the cable is not fixed prior to screw the sensor into the suitable process connection.
- Feed the special cable through the glands, arrange proper length of cable and fasten the cable with the glands.
- Excessive cable parts have to be wound on a pipe with a min. diameter of 100 mm.

The special cable must not be cut short!

- Let the probe down to the lowest possible point, as only the height of the liquid above the probe will be measured.

For connecting the special breathing cable and the signal cable use the cable terminal box **NAA-101** or **NAA-102** (with IP65), that accommodates the cable end in an ambience free of dust and humidity. Fasten the cable terminal box (e.g. by the use of 2 pcs of M4 screw) to a plain surface. In open air or industrial applications the transmitter should be protected against transient surges / overvoltage.

The GND of the OVP must be connected with the shortest possible wire to the protecting ground. In this case it is suggested the **NAA-102** terminal box (with OVP) is installed close to the location of the measurement.

At the opposite end of the cabling the use of an additional over-voltage protection (**OVP 22 / 33** or **OVP 32 / 33**) is advised close to the processing unit.

If safety is a priority, use of a protecting electrode enhances the efficiency of the electrical protection!

In case of Ex devices the **OVP 22 / 33** and **OVP 32 / 33** overvoltage protection unit must not be used!

MOUNTING EXAMPLE

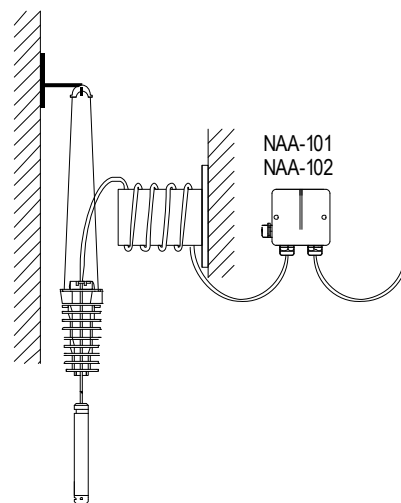

3.1 TERMS AND CONDITIONS FOR APPLICATION IN DRINKING WATER SUPPLY (ONLY IN HUNGARY)

The following terms and conditions are required for the use of the **NIVOPRESS NP, NZ** and **NF** type hydrostatic level transmitters in drinking water supply, domestic hot water-supply and bathwater-supply applications.

- The water temperature must not exceed 60 °C, or in case of **NZ** probe 30 °C.
- Before use of the hydrostatic level transmitter, the cleaning and disinfection of the surface must be carried out according to the related regulations of the application area. The applied cleaning detergent may not cause any damage to the hydrostatic level transmitter or in its material. For cleaning and disinfection only detergents or disinfectants authorized by the Office of the Chief Medical Officer (OCMO) may be used.
- It is recommended to rinse the device before use to remove surface deposits! The rinsing water has to be purged into the drain and must not be used for household purposes. The usage of the product in the named applications is only allowed after these precautions.

4. WIRING

| 2-WIRE LEVEL 4 – 20 mA | 3-WIRE LEVEL 0 – 10 V | 2-WIRE 4 – 20 mA + Pt100 | LEVEL + TEMPERATURE 4 – 20 mA + HART® |
|---------------------------|--------------------------|-----------------------------|------------------------------------------|
| | | | |

LEGEND:

| | CABLE CORE | COLOUR |
|---|------------------------------------------------------------------------------------------------------------------------------------------------------------------------|---------------------------------------------------|
| 1 | Shielding | Yellow |
| 2 | Positive power supply | Red |
| 3 | Negative power supply, Voltage output (-) | Black with an additional blue-coloured insulation |
| 4 | NPH / NZH (3-wire) types: Voltage output (+); NPP / NZP types: Pt100 sensor current drive; NPD / NZD types: positive power supply of the temperature transmitter | Uncoloured |
| 5 | NPP / NZP types: Pt100 sensor current drive; NPD / NZD types: negative power supply of the temperature transmitter | Uncoloured + blue shrinkable tube |
| 6 | NPP / NZP types: Pt100 sensing | Black |
| 7 | NPP / NZP types: Pt100 sensing | Black / red |
| L | Breathing capillary with vapour filter | - |

2-WIRE 4 – 20 mA

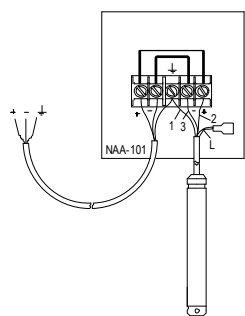

wiring of NAA-101

3-WIRE 0 – 10 V DC

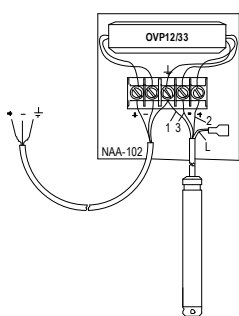

wiring of NAA-102

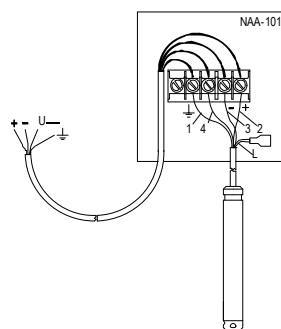

WIRING OF OVP 22 / 33

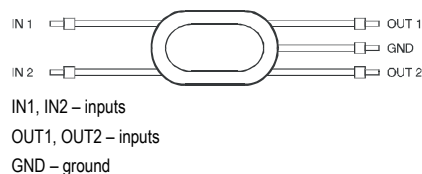

WIRING OF OVP 32 / 33

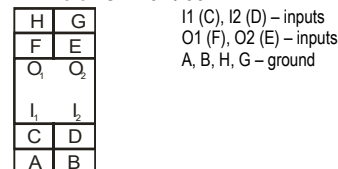

Installation example using Over Voltage Protection units

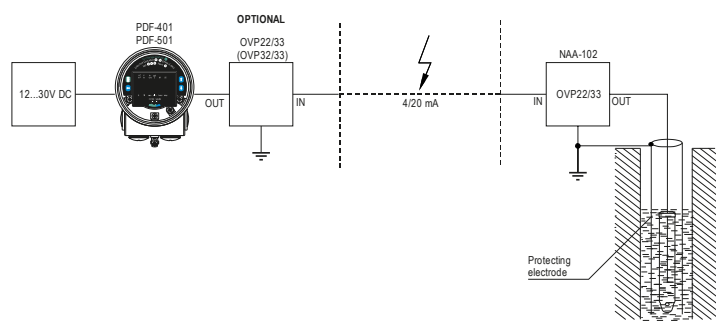

4.1 SPECIAL CONDITIONS FOR SAFE USE

The hydrostatic level transmitters with Ex ia IIC and Ex ia IIB protection type can only be used in intrinsically safe loops powered by a certified power supply with the previously given technical data.

The metal housing of the device must be connected to the EP network using the connection cable marked with 1. The maximum length of connection cable to the transmitter is 5 m (16.4 ft).

5. PUTTING INTO OPERATION, CONFIGURATION

The unit installed and wired according to the specification is immediately operable, however the specified accuracy will be reached in six-hour time with short cable and in twenty-four-hour time with a cable of 300 m (985 ft) length. If correction of insertion length is needed loosen the cable holding sliding sleeve then place the probe to the desired level and finally fasten the cable holding sliding sleeve.

5.1 HART® OUTPUT

HART® capable transmitters are able to communicate using standard HART® commands with NIVELCO's MultiCONT universal process controller or through a HART®-USB modem with a PC and remote programming can be done with the EView2 configuration software. The MultiCONT can power the transmitters, provides remote programming possibility and the measurement values can be transmitted on RS485 communication line if needed. (See the details in the User's and Programming manual of MultiCONT).

The current output of the units can be also configured with the EView2 software in the pressure range from 2% to 130%.

The damping time of the units can be also configured with the EView2 software or with any HART® standard programming interface. The damping time is a time constant of a time period. Its minimal value: 0 sec., maximal value: 99 sec.

5.2 DESCRIPTION OF PARAMETERS AND PROGRAMMING

P0:- - a Pressure value assigned to 4 mA

P1:- - a Pressure value assigned to 20 mA

P0 and P1 pressure values can be assigned to the 4 mA and 20 mA current output values.

When changing the factory set values make sure that the entered values fall within the specified range of the pressure transmitter otherwise the instrument will indicate error.

FACTORY DEFAULT:

P0 = [minimum measurable pressure value of the sensor] mmH₂O (usually 0000)

P1 = [maximum measurable pressure value of the sensor] mmH₂O (usually the possible max. value of the measurement range)

P9: Current generator test (mA)

With this parameter the user can test the current output by entering a value between 3.9 mA and 20.5 mA and test it with an ammeter.

Warning: the test mode can be cancelled only by entering 0000 to P9.

P10:- - a Measuring mode

| a | | Measuring mode |
|---|---------------------|--------------------|
| 0 | mbar | Pressure |
| 1 | psi | |
| 2 | mm H ₂ O | Level (water head) |
| 3 | ft H ₂ O | |
| 4 | cm H ₂ O | |
| 5 | m H ₂ O | |

FACTORY DEFAULT: P10 = 2

P12:- - a Error indication by the current output

| a | Error indication |
|---|------------------|
| 0 | < 3.9 mA |
| 1 | > 21 mA |

FACTORY DEFAULT: P12 = 0

P13: HART® short address (Polling address)

If multiple HART® capable transmitters are used in a loop the instruments have to be distinguished by their polling addresses. If polling address is 0 (default) the current output is 4 – 20 mA and HART® communication works on the 4 – 20 mA current signal. Conforming to the HART® standard max. 15 HART® devices can be connected to a HART® loop with polling addresses between 1 and 15. Thus the output current will be set to 4 mA and only the digital HART® communication will work. Instruments connected to the same loop should not have same polling addresses or 0 polling address set.

FACTORY DEFAULT: P13 = 0

P24: Damping Time

There is the possibility to set output damping time. Damping time is a constant value set a time period. The minimum value is 0 seconds, the maximum is 99 seconds.

FACTORY DEFAULT: 0

6. MAINTENANCE, REPAIR

In NPK types in some instances, the probe may need occasional cleaning to remove surface deposits within the protective cap that can be easily snapped off. During cleaning, do not touch the sensor membrane!

In the case of threaded type probes, the membrane shield cap must be squeezing out before cleaning, and then the filter behind it should be removed. During cleaning, do not touch the sensor membrane!

7. STORAGE CONDITIONS

Ambient temperature: -10 °C ... +50 °C

Relative humidity: max. 85%

npk4110a0600h_05
January 2018