

Thank you for choosing NIVELCO instrument
We are sure that you will be satisfied throughout its use!

NIPRESS

DRF-7□□-□
 PRESSURE TRANSMITTER

1. APPLICATION

The **NIPRESS D-700** series pressure transmitters measure pressure and convert it into voltage and current output. They can be used in 2- and 3-wire systems. The wide choice of the models and accuracy classes makes it suitable for the most pressure measurement tasks when static or dynamic measurement is required.

The design of the transmitter, its overload capability and wide range of temperature and the possibility to install the unit in any position allows their application in the most different industrial circumstances.

2. TECHNICAL SPECIFICATION

TYPE		DRF-7□□-□
Measurement range		0 – 20 bar according to the order code
Overload capability		According to the order code
Accuracy		0.5%; Pn ≥ 0.6 bar: 0.25%; 1% (with Teflon coating)
Medium temperature		- 40 °C ... + 125 °C *
Ambient temperature		- 40 °C ... + 85 °C *
Sensor type		Piezoresistive
Materials of the wetted parts	Sensor	aluminium oxide ceramic (flush membrane) **
	Sensor sealing	FKM: - 40 °C ... + 125 °C FFKM: - 15 °C ... + 125 °C; EPDM: - 40 °C ... + 125 °C
	Process connection	stainless steel DIN 1.4404 ** optional PVDF
	Housing	stainless steel DIN 1.4404 ** optional PVDF
Output		4 – 20 mA; 0 – 10 V
Power supply		4 – 20 mA output: 9 – 32 V DC; 0 – 10 V DC output: 12.5 – 32 V DC
Load resistance		4 – 20 mA 2-wire current output $R_t \leq \frac{U_t - 9V}{0,02A} \Omega$ 0 – 10 V voltage output $R_t > 10 k\Omega$
Process connection		1 1/2" BSP
Electrical connection		Pg 9 DIN 43650 connector / M12x1 / with integral cable
Ingress protection		IP65 / IP67 (M12x1) / IP68 (with integrated cable)
Electric protection		SELV Class III
Mass		~ 0.2 kg

* Minimum temperature with PVDF process connection is -30 °C

** Optional: Teflon coating (with 1% accuracy)

User's manual



2.1 ACCESSORIES

- User's manual
- Warranty Card
- Declaration of Conformity

2.2 ORDER CODE

NIPRESS D R F - 7 □ □ - □

RANGE (OVERLOAD CAPABILITY) BAR	CODE	CODE
0 – 0.04	(2)	O
0 – 0.06	(2)	P
0 – 0.1	(4)	1
0 – 0.16	(4)	R
0 – 0.25	(6)	2
0 – 0.4	(6)	3
0 – 0.6	(8)	4
0 – 1	(8)	5
0 – 1.6	(15)	6
0 – 2.5	(25)	7
0 – 4	(25)	8

RANGE (OVERLOAD CAPABILITY) BAR	CODE	CODE
0 – 6	(35)	9
0 – 10	(35)	A
0 – 16	(45)	B
0 – 20	(45)	T

OUTPUT	CODE
4 – 20 mA	2
0 – 10 V	3

ACCURACY	CODE
0.25% ⁽¹⁾	1
0.5%	2
1% ⁽²⁾	3

⁽¹⁾ over 0,6 bar

⁽²⁾ with Teflon coating

2.3 DIMENSIONS

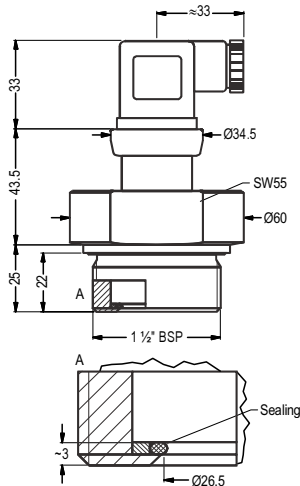

1 1/2" BSP (DIN 3852) stainless steel

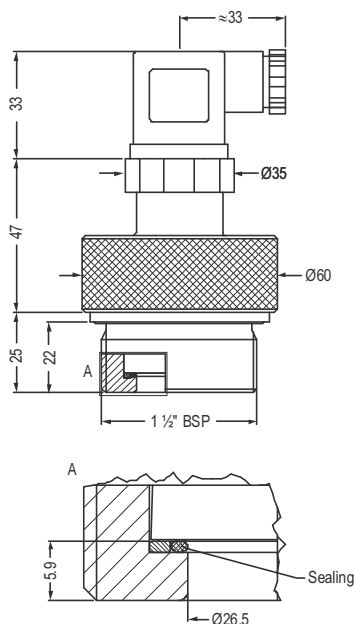

1 1/2" BSP (DIN 3852) PVDF

3. MOUNTING

Due to its small size and weight NIPRESS D-700 can be directly installed on tanks, pipes, machines, etc without mounting device.

To provide chance for replacement of the instrument during operation the use of closing armature is recommended. A simple ball valve will be suitable for lower pressure and for higher pressure (above 6 bar g) a three-way blow-off needle-valve can be suggested. With pressure measurements of medium with temperature over 75°C, the application of condensing device would protect the instrument against overheating and extends its lifetime.

Temperature of the condensation in the condensing devices (in the water lodge) is practically only 10 ... 20°C higher than the ambient temperature. Using longer impulse tube its proper sloping for the necessary de-aerating and emptying has to be ensured.

Measuring low pressure values in systems with substantial height difference between the transmitter and place of measurement the hydrostatic pressure of the medium in the impulse pipe should be taken into consideration. In the case of outside installation, the unit is supposed to be protected against rain or splash water.

3.1 INSTALLATION

First, make sure that the O-ring fits perfectly and is not damaged. The sealing has to be clean with smooth surface.

Screw the device into the corresponding thread by hand.

The cylindrical housing of the transmitter should not be gripped and tightened with pipe wrench!

The plug-in electric connector (DIN version) can be unplugged after releasing and removing its fastening screw. The connection insert can be pushed out by a screw driver from the direction of the screw. The connection insert can be rotated in the housing by 90° which makes it possible to the device to be installed with the pressure connection up so the liquid can drain off the case.

Pushing electric cable through the cable gland it can be connected to the relevant points of the connector. Make sure that the cable gland and sealing plate of the connector will be tight.

For the sake of noise suppression, the transmitter housing is grounded. If the grounding of the appliance with the pressure transmitter is appropriate no further action will be needed. If not, the grounding should be performed.

4. WIRING

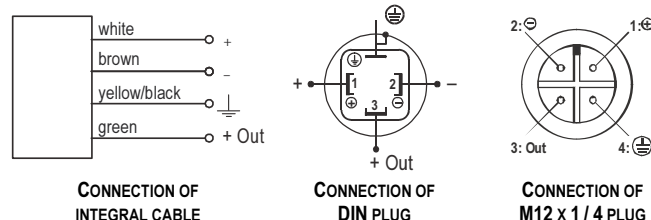

4.1 EXAMPLES OF ARRANGEMENTS

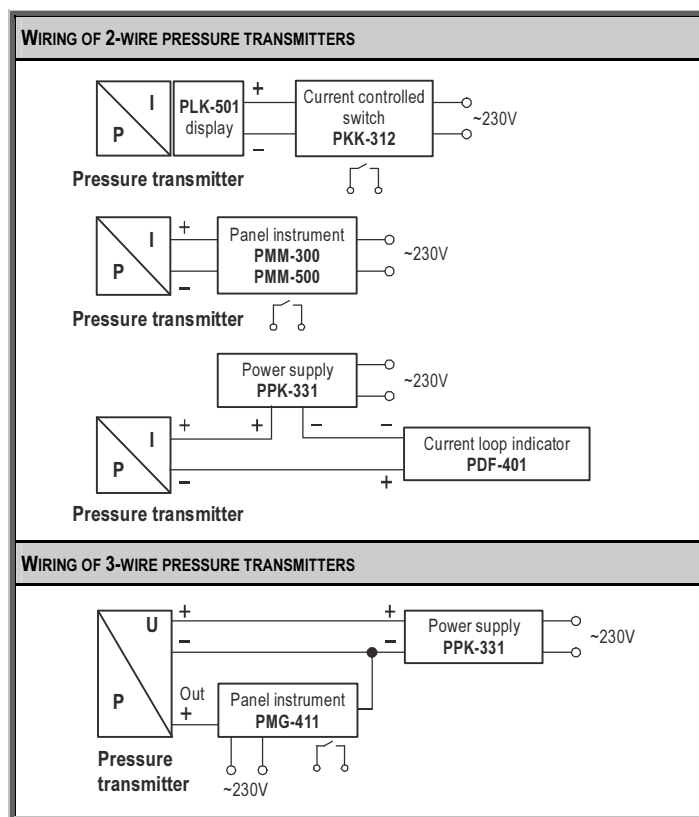

5. MAINTENANCE AND REPAIR

The instrument does not require regular maintenance. If necessary possible dirt deposited should be cleaned off. With certain media, however, the diaphragm may be polluted or coated with deposit. It is recommended to define corresponding service intervals for control. After placing the device out of service correctly, the diaphragm can usually be cleaned carefully with a non-aggressive cleaning solution and a soft brush or sponge.

6. STORAGE CONDITIONS

Storage temperature: - 40 °C ... + 100 °C

Relative humidity: max. 98 %

7. WARRANTY

NIVELCO provides warranty of 3 (three) years in compliance with details described in the Warranty Card.

drf7612a0600h_03
September 2017.