



AnaCONT

LE-100

LG-100

LP-100

Two-wire compact analytical transmitters

Installation and Programming manual

6th edition



**pH- and ORP-
sensors and transmitters (compact type)**



**Dissolved oxygen
sensors and transmitters (compact type)**



**pH- and ORP-
sensors and transmitters (integrated type)**



**Dissolved oxygen
sensors and transmitters (integrated type)**

TABLE OF CONTENTS

1. INTRODUCTION	5
1.1. APPLICATION	5
1.2. OPERATION PRINCIPLE	5
1.2.1. <i>Characteristics of an ideal pH electrode</i>	5
1.2.2. <i>Characteristics of an ideal ORP electrode</i>	6
1.2.3. <i>Characteristics of an ideal DO sensor</i>	6
2. ORDER CODES	7
2.1. CONFIGURATIONS	11
3. TECHNICAL DATA	16
3.1. TECHNICAL DATA OF THE PH ELECTRODES (INCLUDING EX VERSIONS) FOR LQP-□□□-□ INSTRUMENTS	18
3.2. TECHNICAL DATA OF THE ORP ELECTRODES (INCLUDING EX VERSIONS) FOR LOR-□□□-□ INSTRUMENTS	20
3.3. TECHNICAL DATA OF THE DO SENSORS (INCLUDING EX VERSIONS) FOR LOD-□□□-□ INSTRUMENTS	22
3.4. ACCESSORIES	22
4. MAINTENANCE AND REPAIR	23
4.1. STORAGE	23
4.2. PERIODIC SETTING, CALIBRATION AND VERIFICATION	23
4.2.1. <i>Periodic calibration of the pH electrode</i>	24
4.2.2. <i>Verification of the ORP electrode</i>	25
4.2.3. <i>Periodic calibration of the DO sensor</i>	25
4.3. MAINTENANCE OF THE PH AND ORP ELECTRODES	27
4.4. MAINTENANCE OF THE DO SENSOR	29
4.5. SOFTWARE UPDATE	29
5. INSTALLATION	30
5.1. MOUNTING	30
5.1.1. <i>Installation of pH and ORP electrodes</i>	30
5.1.2. <i>Installation of DO sensor</i>	31
5.1.3. <i>Special application possibilities of the Integrated type instruments</i>	33
5.1.4. <i>Installing extension units</i>	34
5.2. WIRING	37
5.2.1. <i>Wiring of Compact instruments</i>	37
5.2.2. <i>Wiring of Integrated instruments</i>	38
5.3. LOOP CURRENT CHECKING WITH HAND INSTRUMENT	38
5.4. CONDITIONS OF EX APPLICATION	38

6. PROGRAMMING	39
6.1. THE SAP-300 DISPLAY UNIT	39
6.2. MEASURING WITH THE SAP-300 DISPLAY UNIT	40
6.3. PROGRAMMING WITH THE SAP-300 DISPLAY MODULE	43
6.3.1. <i>Components of the programming interface</i>	<i>43</i>
6.3.2. <i>Menu structure.....</i>	<i>44</i>
6.4. PROGRAMMABLE FEATURES DESCRIPTION.....	45
6.4.1. <i>Basic measurement settings</i>	<i>45</i>
6.4.2. <i>Analogue output</i>	<i>47</i>
6.4.3. <i>Relay output</i>	<i>48</i>
6.4.4. <i>Digital output.....</i>	<i>50</i>
6.4.5. <i>Service functions</i>	<i>50</i>
6.5. PH SENSOR CALIBRATION	56
6.5.1. <i>Editing one item of the calibration table</i>	<i>56</i>
6.5.2. <i>Adding an item to the calibration table</i>	<i>58</i>
6.5.3. <i>Deleting an element of the calibration table.....</i>	<i>58</i>
6.5.4. <i>Reset the calibration table to default.....</i>	<i>58</i>
6.5.5. <i>Calibration procedure</i>	<i>58</i>
6.6. DO SENSOR CALIBRATION	59
6.6.1. <i>Calibration of saturated value (100%).....</i>	<i>59</i>
6.6.2. <i>Calibration of Zero point (0%)</i>	<i>60</i>
6.6.3. <i>Calibration with referential DO instrument</i>	<i>60</i>
6.6.4. <i>Reset the calibration table to default.....</i>	<i>60</i>
6.6.5. <i>Reset Timer.....</i>	<i>60</i>
6.7. ERROR CODES	61

Thank you for choosing a NIVELCO instrument.
We are sure that you will be satisfied throughout its use!

1. INTRODUCTION

1.1. APPLICATION

The **AnaCONT** compact transmitters, liquid analytical instruments are suitable for high precision measurement and transmission of acidity or alkalinity - pH (Hydrogen ion concentration) value -, reducing and oxidizing capability - ORP (Oxidation Reduction Potential) value -, or Dissolved Oxygen content of process water, wastewater, surface water, ground water and drinking water. These measurements can be widely used in industrial practice and could be of great relevance. In the field of environmental protection or sewage treatment, instruments like that are suitable for measuring the concentration of hazardous substances (chromium, cyanide). In chemical- and pharmaceutical industry, high precision measurement has utmost importance in the aspect of the technology (e.g. solvent feed), in many cases it is quality specification standard.

1.2. OPERATION PRINCIPLE

The intelligent signal processing of the electronics calculates the output signal from the voltage output values of the electrode and the temperature probe, and compensates it to 25°C. This value composes the basis of all output signals of the instrument.

1.2.1. Characteristics of an ideal pH electrode

The pH electrode immersed in the measured liquid measures a voltage value which is proportional to the hydrogen ion concentration of the liquid.

- 0mV output at neutral pH value (pH=7.00)
- Positive voltage output in acidic liquids (pH<7)
- Negative voltage output in alkaline liquids (pH>7)
- Total measuring range is 0-14pH
- -59.16mV/pH (Nernst potential) slope at 25 °C
- The temperature dependency of the Nernst potential is -0.001984 mV / °C.

Because the pH electrodes in deed are not ideal (their properties depend on the design of the electrode, manufacturing tolerances and most of all the age of the electrode) the parameters differ from the given values above. To achieve reliable pH measurement and accuracy these electrodes must be calibrated from time to time. The time interval between two calibrations depends on the application conditions where the pH probes are used. Calibration of pH electrodes means offsetting the displayed value (7.00pH) when gauging neutral buffer solution, and adjusting the slope (pH/mV) by measuring buffer solutions with other pH value (usually with 4.00pH and 10.00pH value) by adjusting the displayed value to exact 4.00 and 10.00pH, respectively.

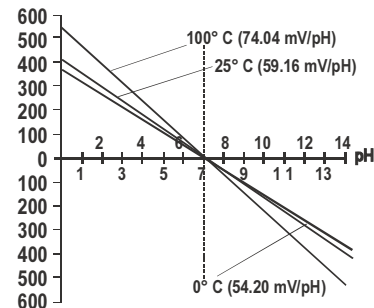

1.2.2. Characteristics of an ideal ORP electrode

- Negative voltage output in liquids with reduction potential,
- Positive voltage output in liquids with oxidation potential,
- Output voltage is equal to the redox potential (according to the Nernst equation)
- pH independent measurement with certain types

To achieve reliable measurement and accuracy, these electrodes have to be thoroughly checked before installation and during usage from time to time. The time interval between two calibrations depends on the application and conditions where the ORP probes are used.

1.2.3. Characteristics of an ideal DO sensor

The dissolved oxygen level indicates the amount (in mg/l or ppm) of physically dissolved gas-form oxygen in liquid phase.

Oxygen-permeable membrane amperometric DC sensor wetted in the measurement medium gives output current proportional to the dissolved oxygen concentration of the medium.

The ideal DO sensor has:

- $i_{\text{zero}}=0$,
- Temperature independent output current

Real DO sensor gives off a minimal $i_{\text{zero}} \neq 0$ ppm current in case of 0 ppm dissolved oxygen concentration and its oxygen-permeable capability is temperature-dependent. Oxygen-permeable capability of the membrane is increasing according to the increase of the temperature, at 25 °C it can be 4%/°C. Temperature proportional correction is necessary for reliable measurement.

The DO sensors in deed are not ideal (their properties depend on the design of the electrode, manufacturing tolerances and most of all the age of the electrode), so the parameters differ from the given values above. To give reliable DO measurement and accuracy these electrodes must be calibrated from time to time. In case of DO sensors the calibration means that 0 ppm output value have to be set by offsetting in an oxygen-free solution. For DO measurement of other mediums (for example dry air 20.95% @25°C or oxygen-saturated water) adjustment of slope (nA/ppm) has to done accurately according to the properties of these mediums.

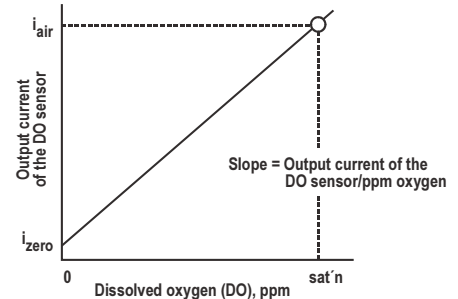

2. ORDER CODES

Not all combinations possible!

AnaCONT instruments:

AnaCONT L - - *

TYPE	CODE
Transmitter	E
Transmitter + display	G
Integrated	P

FUNCTION	CODE
pH	P
ORP	R
DO	D

HOUSING	CODE
Plastic	1
Aluminium	2

PROBE**

PROC. CONN. / MATERIAL	CODE
BSP 1½" / PP	1
BSP 1½" / PVDF	2
NPT 1½" / PP	4
NPT 1½" / PVDF	5

OUTPUT	CODE
4 ... 20 mA	2
4 ... 20 mA / HART	4
4 ... 20 mA / Ex	6
4 ... 20 mA / HART / Ex	8
4 ... 20 mA / Relay	R
4 ... 20 mA / HART / Realy	H

PH PROBE	CODE
4xpher112seph	1
4xphed112seph	2
4xphe112seph	3
4xpheph314sph	4
4xphe1120seph	5
4xphes112seph	6
4xphep112seph	7
4xphek112seph	8

ORP PROBE	CODE
4xorrherpseor	1
4xorrhexpseor	2
4xorrheptseor	3
4xorrhespseor	4
4xorrheppseor	5
4xorrhek1seor	6

DO PROBE	CODE
4x085g0023ydo / 20ppm	1
4x085g0022ydo / 10ppm	2

* The order code of an Ex version should end in "Ex"!

** Probe selection is detailed in 3rd chapter.

The extension unit, adjustment unit and the sensor housing can be ordered to every analytical device, apart from the type of the electrode, measurement principal and measured quantity. Sensor protection tube is available only for L□P-□□□-□, or L□R-□□□-□ instruments.

EXTENSIONS L A □ - □ □ □ - 0

TYPE	CODE
Pipe	R
Cable	K
Suspended pipe	F

MATERIAL	CODE
PP	1
PVDF	2

CODE	LENGTH (L)		CODE
0	0 m	0 m	0
1	1 m	0.1 m	1
2	2 m	0.2 m	2
3	3 m	0.3 m	3
4	4 m	0.4 m	4
5	5 m	0.5 m	5
6	6 m	0.6 m	6
7	7 m	0.7 m	7
8	8 m	0.8 m	8
9	9 m	0.9 m	9
A	10 m		

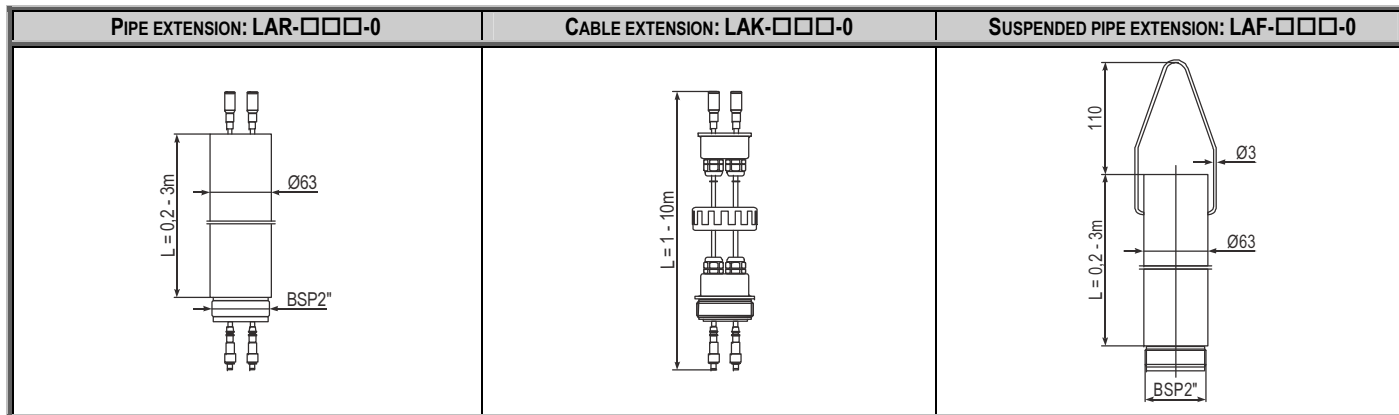

SLIDING SLEEVE: L A A - 1 0 - 0

	CODE
DN80 PN16 / PP	2
DN100 PN16 / PP	3
DN125 PN16 / PP	4
DN150 PN16 / PP	5
DN200 PN16 / PP	6
Console mounting bracket, 200 mm	K
Mounting bracket, 200 mm	T

SLIDING SLEEVE WITH FLANGE: LAA-10 -0

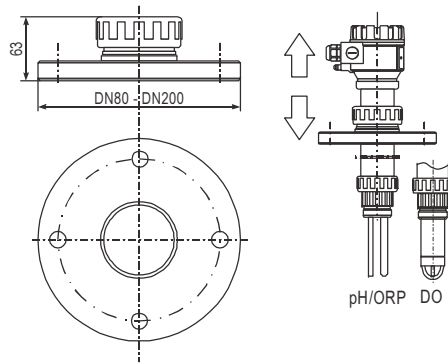

CONSOLE MOUNTING BRACKET: LAA-10K-0

MOUNTING BRACKET: LAA-10T-0

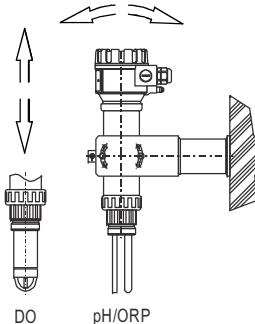
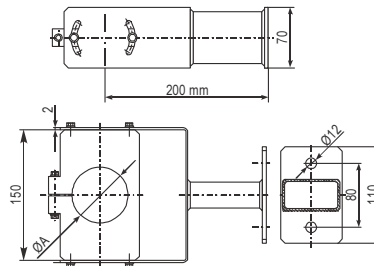

**FOR EXTENSION TYPE
ØA = 63.5MM**

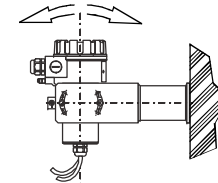

**FOR BASIC TYPE
ØA = 70.5MM**

SENSOR PROTECTION TUBE: L A P

	MATERIAL
1	PP
2	PVDF

	SIZE
1	1½"
2	2"

0 - 0

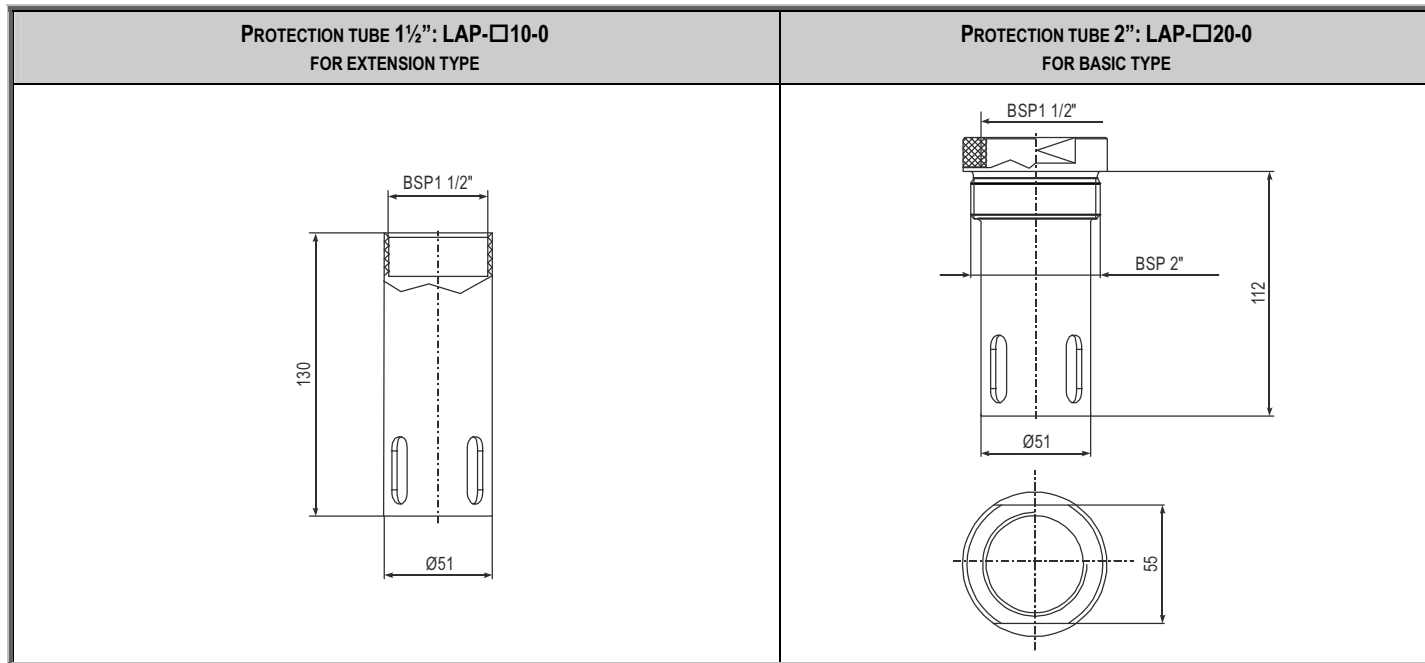

Sensor protection tube is available only for L□P-□□□-□, or L□R-□□□-□ instruments

2.1. CONFIGURATIONS

COMPACT STANDARD TYPE: ANACONT LE□-□□□-□,
LG□-□□□-□
(+SENSOR PROTECTION TUBE: LAP-□20-0)*

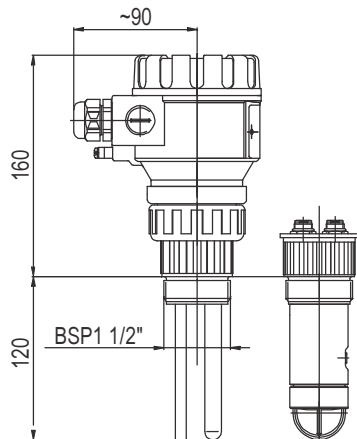

INTEGRATED STANDARD TYPE: ANACONT LP □-□□□-□
(+SENSOR PROTECTION TUBE: LAP-□20-0)*

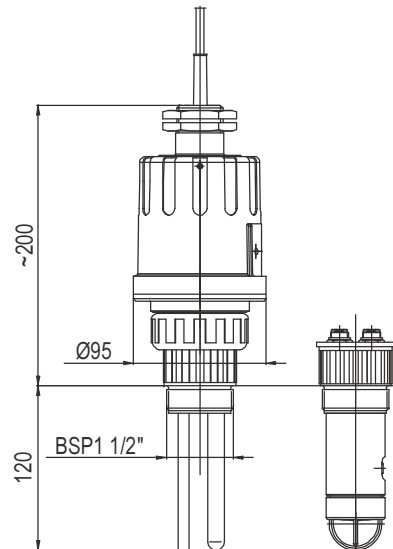

*Further configuration drawings show only compact types, however many accessories are available to order with integrated types.
Essential dimension values are shown in the drawings of the standard types.

STANDARD TYPE: ANACONT L□□-□□□-□
(+SENSOR PROTECTION TUBE: LAP-□20-0)*

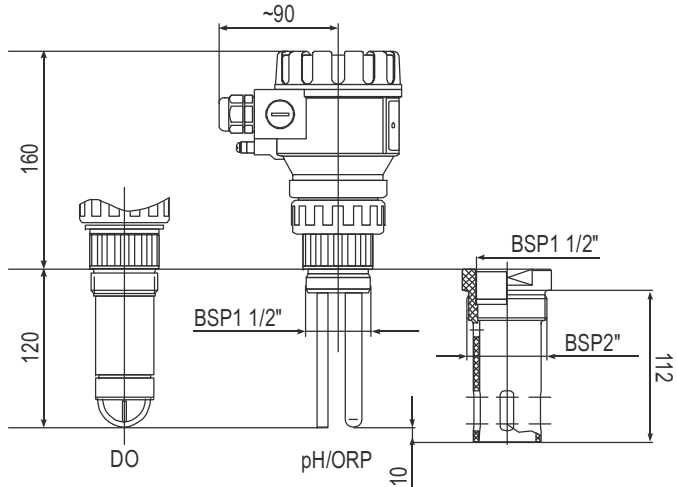

STANDARD TYPE: ANACONT L□□-□□□-□
+ PIPE EXTENSION: LAR-□□□-0
(+SENSOR PROTECTION TUBE: LAP-□10-0)*

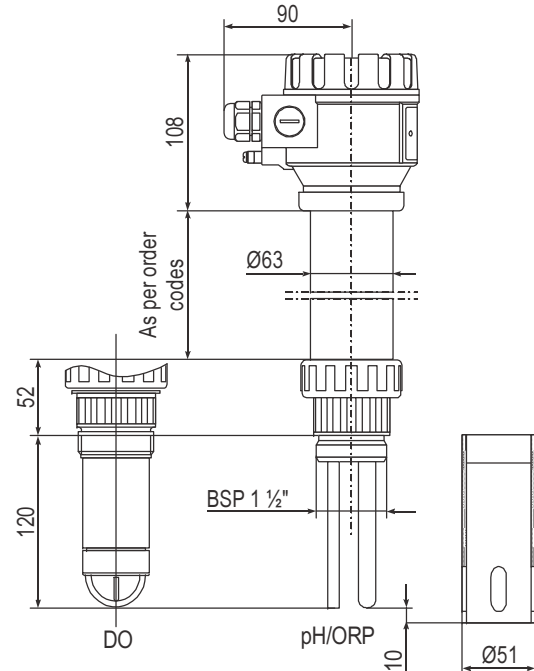

* Sensor protection tube is available only for L□P-□□□-□, or L□R-□□□-□ instruments.

STANDARD TYPE : ANACONT L□□-□□□-□
+ PIPE EXTENSION : LAR-□□□□-0
+ SLIDING SLEEVE WITH FLANGE : LAA-10□□-0
(+SENSOR PROTECTION TUBE : LAP-□□10-0)*

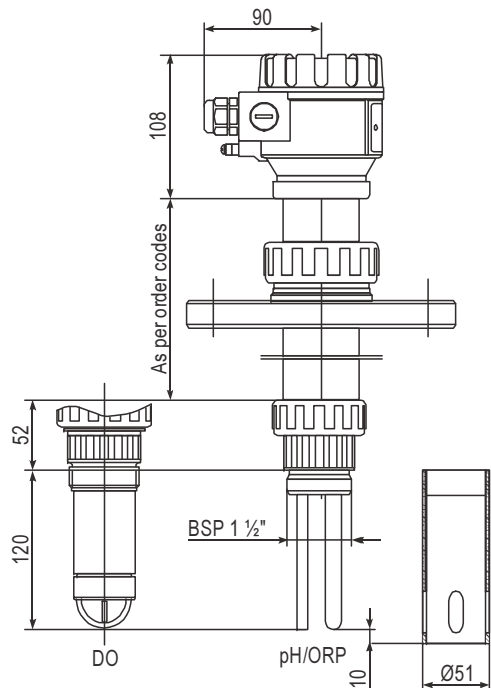

STANDARD TYPE : ANACONT L□□-□□□-□
+ PIPE EXTENSION : LAR-□□□□-0
+ CONSOLE MOUNTING BRACKET : LAA-10K-0
(+SENSOR PROTECTION TUBE : LAP-□□10-0)*

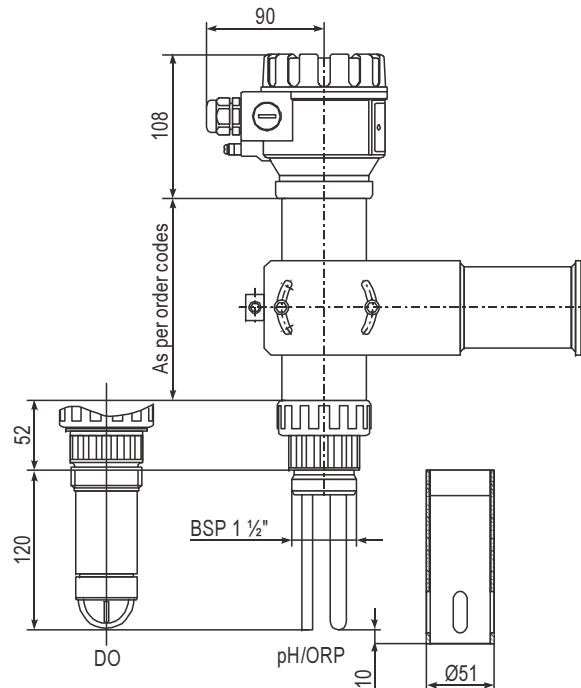

* Sensor protection tube is available only for L□P-□□□□-□, or L□R-□□□□-□ instruments.

STANDARD TYPE ANACONT L□□-□□□-□

+ CABLE EXTENSION: LAK-□□□-0

(+SENSOR PROTECTION TUBE: LAP-□20-0)*

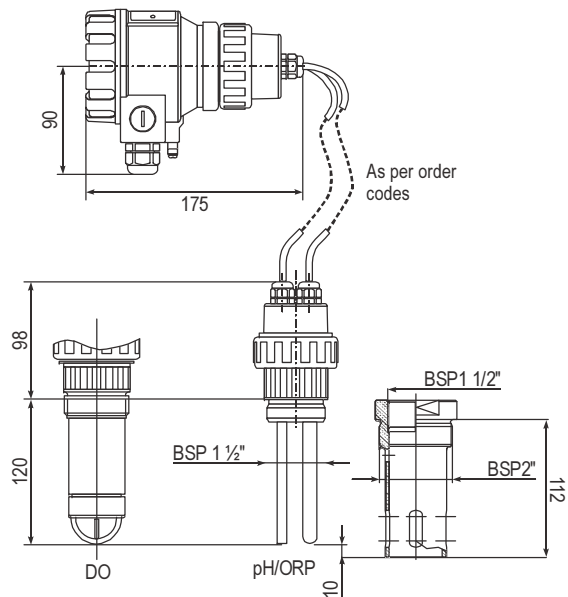

STANDARD TYPE: ANACONT L□□-□□□-□

+ CABLE EXTENSION: LAK-□□□-0

+ SUSPENDED PIPE EXTENSION: LAF-□□□-0

(+SENSOR PROTECTION TUBE: LAP-□10-0)*

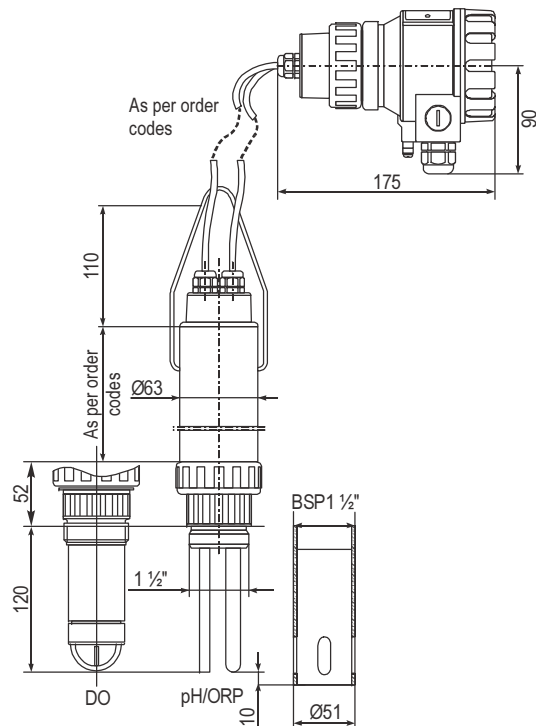

* Sensor protection tube is available only for L□P-□□□-□, or L□R-□□□-□ instruments.

STANDARD TYPE: ANACONT L□□-□□□-□
 + CABLE EXTENSION: LAK-□□□-0
 + SUSPENDED PIPE EXTENSION: LAF-□□□-0
 + SLIDING SLEEVE WITH FLANGE: LAA-10□-0
 (+SENSOR PROTECTION TUBE: LAP-□10-0)*

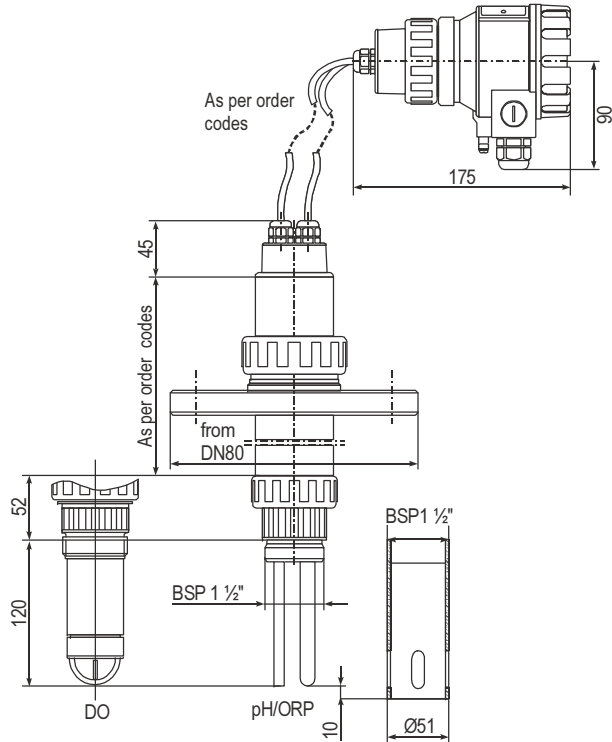

STANDARD TYPE: ANACONT L□□-□□□-□
 + CABLE EXTENSION: LAK-□□□-0
 + SUSPENDED PIPE EXTENSION: LAF-□□□-0
 + CONSOLE MOUNTING BRACKET: LAA-10K-0
 (+SENSOR PROTECTION TUBE: LAP-□10-0)*

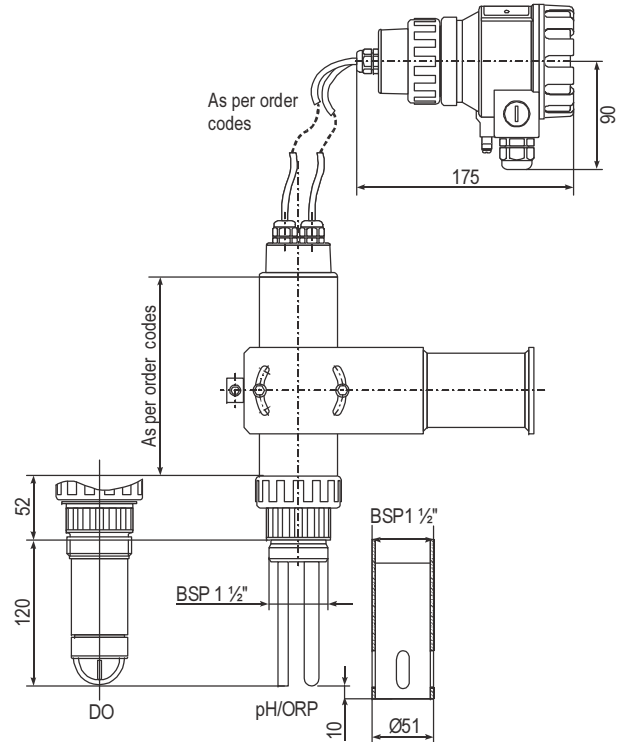

* Sensor protection tube is available only for L□P-□□□-□, or L□R-□□□-□ instruments.

3. TECHNICAL DATA

GENERAL DATA

Material of sensor housing	Polypropylene (PP), PVDF
Electrode	As per order code
Housing material	Compact type: Plastic: Glass fibre plastic PBT Metal: Powder paint coated Aluminium Integrated type: Same as the sensor housing
Medium temperature (pressure dependent) *	PP sensor housing: -10 °C ... +90 °C, PVDF sensor housing: -15 °C ... +100 °C with DO probe: 0 °C ... +50 °C
Ambient temperature	Metal housing: -30 °C ... +70 °C, Plastic housing: -25 °C ... +70 °C, both with display: -20 °C ... +70 °C
Pressure (absolute)*	With pH and ORP probe: 0.05 ... 1 MPa (0.5 ... 10 bar) @25°C With DO probe: 0,1...0,2 MPa (1...2 bar)@25°C
Sealing	PP sensor housing: EPDM. all other sensor housing: FPM (Viton)
Ingress protection	Compact type: Sensor housing: IP 68, Housing: IP 67 (NEMA 6) Integrated type: IP 68
Power supply / Consumption	12 ... 36 V DC / 48 mW ... 720 mW, galvanic isolation, protection against surge transients
Electrode input	With pH and ORP probe: Combined electrode, galvanic isolation, input impedance: >10 ¹² ohm, connection: SN6. With DO probe: Galvanic isolated current input, 0.725V polarisation voltage, connection: SN6
Liquid potential (complementary) electrode**	Stainless steel housing of the temperature sensor (1.4571) , connection: SN6
Temperature measuring (semiconductive sensor)	Range: -50...130°C, Accuracy: ±0.5°C, Resolution: 0.1°C
Outputs	Analogue: 4 ... 20 mA, (3.9 ... 20.5 mA), R _{max} = 1200 Ω ([U _r - 12 V] / 0.022 A) galvanic isolation, protection against surge transients
	Relay: SPDT 30 V DC, 1A DC
	Display: SAP-300 (128x64 pixels monochrome LCD, 41x24mm with effective display interface)
	Serial line: (optional) HART interface, terminal resistor ≥ 250 ohm
Electrical connections	Compact type: 2 x M20x1.5 metal cable gland, cable diameter: 7 ... 13 mm, or 2 x M20x1.5 plastic cable gland, cable diameter: 6 ... 12 mm; connecting cable cross section: 0.5 ... 1.5 mm ² (shielded cable is recommended) + internal thread 2x NPT 1 / 2" cable protective pipe Integrated type: 6x0.5mm ² shielded cable ∅ 6 mm x 5 m (up to max. 30 m cable length)
Electrical protection	Class III. electric shock protection, less than 24V voltage feed

* Depends on the selected electrode!

**In case of L□P-□□□-□ and L□R-□□□-□ instruments.

MEASUREMENT DATA

pH measurement	Range: 0...14pH, Reserve: ±2pH, Accuracy*: 0.1% of the measured value ±1 digit ±0.01% /°C, Linearity: ±0.004pH, Resolution: 0.01pH, (internal resolution 0.004pH), Measuring cycle: 300msec, on display: 1 sec
ORP measurement	Range: ±1000mV, Reserve: ±200mV, Accuracy*: 0.1% of the measured value ±1 digit ±0.01% /°C, Linearity: ±0.001%, Resolution: 0.1mV, Measuring cycle: 300msec, on display: 1sec
DO measurement	Range: 0...20ppm v. 0...10ppm, Reserve: 20%, Accuracy*: 0.5% of the measurement range ±1 digit ±0.01% /°C, Linearity: ±0.05ppm, Resolution: 0.01ppm, (internal resolution 0.005ppm), Measuring cycle: 300msec, on display: 1sec

* Depends on the selected electrode / sensor!

SPECIAL DATA FOR EX APPROVED MODELS

Ex marking	 II1G Ex ia IIB T6 Ga
Intrinsically safe data	$C_i \leq 15 \text{ nF}$, $L_i \leq 200 \mu\text{H}$, $U_i \leq 30 \text{ V}$, $I_i \leq 140 \text{ mA}$, $P_i \leq 1 \text{ W}$ For Ex transmitter only Ex ia power supply should be used
Ex power supply	$U_o < 30 \text{ V}$, $I_o < 140 \text{ mA}$, $P_o < 1 \text{ W}$, power supply voltage range 12 V ... 30 V, $R_{i \text{ max}} = [U_i - 12 \text{ V}] / 0.022 \text{ A}$
Medium temperature	With pH and ORP probe: for PP sensor housing: -10... +70 °C, PVDF sensor housing: -15... +80 °C With DO probe: : 0... +50 °C
Ambient temperature	Metal housing: -30 °C ... +70 °C with display: -20 °C ... +70 °C, Plastic housing : -20 °C ... +70 °C

3.1. TECHNICAL DATA OF THE pH ELECTRODES (INCLUDING EX VERSIONS) FOR LQP-□□□-□ INSTRUMENTS

Type	4xpher112seph		4xphed112seph		4xphex112seph	
Range [pH]	1...12		1...12		1...12	
Process temperature °C	0...80		0...80		0...100	
Max. process pressure [bar]	6		8		16 (<25°C), 6 (<100°C)	
Min. conductivity µs/cm	50		150		500	
Diaphragm (the conductive aperture of the reference electrode)/electrolyte in closed glass-house	PTFE (Teflon) ring / 3 mol KCl		2 pcs ceramic rod / 3 mol KCl		Concentrical gap/ 3 mol KCl	
Connection / insertion length [mm]	SN6 & PG13,5 / 120		SN6 & PG13,5 / 120		SN6 & PG13,5 / 120	
Main application areas	Public and industrial wastewater, process water, drinking water, water in chemical industry, water with suspended solid particles.		Industrial water, drinking water, slightly contaminated wastewater, cooling tower water, galvanic industry, technologic water with Cr 6+, CN		Wastewater, process water, water in chemical industry, emulsions, suspensions, mediums containing proteins or sulphides, water with high concentration of solid particles.	
Not applicable for	Steam sterilization, water with low conductivity, sudden temperature changes.		Steam sterilization, water with low conductivity, sudden temperature changes.		Steam sterilization, water with low conductivity, sudden temperature changes. Clear water!!	
Type	4xpheph314sph		4xphe112seph		4xphe112seph	
Range [pH]	3...14		1...12		1...12	
Process temperature °C	0...100		0...60		0...60	
Max. process pressure [bar]	6 (<25°C), 3 (<100°C)		0.5		3	
Min. conductivity µs/cm	150		150		150	
Diaphragm (the conductive aperture of the reference electrode)/electrolyte in closed glass-house	Ceramic / 3 mol KCl		Ceramic / 3 mol KCl		Ceramic / 3 mol KCl	
Connection / insertion length [mm]	SN6 & PG13,5 / 120		SN6 & PG13,5 / 120		SN6 & PG13,5 / 120	
Main application areas	Monitoring or controlling of chemical processes of mediums from neutral to very alkaline.		Swimming pools, applications in atmospheric pressure, drinking water, slightly contaminated wastewater.		Swimming pools, applications under pressure, drinking water, slightly contaminated industrial and wastewater.	
Not applicable for	Steam sterilization, water with low conductivity, sudden temperature changes.		Steam sterilization, water with low conductivity, sudden temperature changes, above atmospheric pressure.		Steam sterilization, water with low conductivity, sudden temperature changes	



TYPE	4xphep112seph		4xphek112sph	
Range [pH]	1...12		1...12	
Process temperature °C	0...80		0...60	
Max. process pressure [bar]	6		3	
Min. conductivity µs/cm	150		150	
Diaphragm (the conductive aperture of the reference electrode)/electrolyte in closed glass-house	Ceramic / 3 mol KCl		Ceramic (polycarbonate)	
Connection / insertion length [mm]	SN6 & PG13,5 / 120		SN6 & PG13,5 / 120	
Main application areas	Swimming pools, drinking water, process water, slightly contaminated wastewater, electrolytic metallization.		Swimming pools, drinking water, process water, slightly contaminated wastewater.	
Not applicable for	Steam sterilization, water with low conductivity, sudden temperature changes.		Steam sterilization, water with low conductivity, sudden temperature changes.	



3.2. TECHNICAL DATA OF THE ORP ELECTRODES (INCLUDING EX VERSIONS) FOR L□R-□□□-□ INSTRUMENTS

TYPE	4xorrherpseor	4xorrhexpseor	4xorrheptseor
Process temperature °C	0...80	0...100	0...60
Max. process pressure [bar]	6	16 (<25°C), 6 (<100°C)	1
Min. conductivity µs/cm	50	500	150
Diaphragm (the conductive aperture of the reference electrode)/electrolyte in closed glass-house	PTFE (teflon) ring / KCl	Circular recess / solid electrolyte	Ceramic
Connection / insertion length [mm]	SN6 & PG13,5 / 120	SN6 & PG13,5 / 120	SN6 & PG13,5 / 120
Main application areas	public and industrial wastewater process water drinking water water in chemical industry water with suspended solid particles	polluted water emulsions, mediums containing sulphides high pressure applications	drinking water pools in atmospheric pressure slightly polluted water
Not applicable for	steam sterilization water with low conductivity sudden temperature changes	steam sterilization water with low conductivity sudden temperature changes clean water	steam sterilization water with low conductivity sudden temperature changes



TYPE	4xorrhespseor		4xorrhheppseor		4xorrheklseor
Process temperature [°C]	0...60		0...80		0...60
Max. process pressure [bar]	3		6		3
Min. conductivity [µs/cm]	150		150		150
Diaphragm / electrolyte	Ceramic		Ceramic		Ceramic (polycarbonate housing)
Connection / insertion length [mm]	SN6 & PG13,5 / 120		SN6 & PG13,5 / 120		SN6 & PG13,5 / 120
Main application areas	swimming pools drinking water slightly polluted water		slightly polluted water drinking water process water swimming pools metallization chemical applications		swimming pools drinking water slightly polluted water
Not applicable for	steam sterilization water with low conductivity sudden temperature changes		steam sterilization water with low conductivity sudden temperature changes above atmospheric pressure mediums containing ozone		steam sterilization water with low conductivity sudden temperature changes

3.3. TECHNICAL DATA OF THE DO SENSORS (INCLUDING EX VERSIONS) FOR L□D-□□□-□ INSTRUMENTS

TYPE	4x085g0023ydo (20 ppm)	4x085g0022ydo (10 ppm)
DO range [ppm]	0...20	0...10
Process temperature [°C]	0...50	0...50
Max. process pressure [bar]	1	1
Min. speed of medium-flow [m/s]	0,05	0,05
Response time [sec]	110	22
Accuracy [%; ppm]	±0.5 ; 0.1	±0.5 ; 0.05
Life-span [year]	2-3	2-3
Material/thickness of the membrane	PTFE / 125µm	PTFE / 50µm
Other materials	PBT/PC, gold, silver, silver-chloride, potassium-chloride	PBT/PC, gold, silver, silver-chloride, potassium-chloride
Application area	Fish- and crawfish farms, water conditioning of large aquariums, Controlling of oxygen concentration in water-plants, determination of biological condition in surface water	Potable water production, river monitoring, water treatment sites, controlling of dissolved oxygen level in wastewater plants, determination of biological condition in surface water.

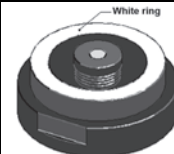

SAP-300 DISPLAY UNIT

Display	128 x 64 pixels monochrome LCD, with 41x24mm effective display surface
Ambient temperature	- 20°C... +70°C
Storage temperature	- 30°C... +80°C
Housing material	PBT fibre glass plastic

3.4. ACCESSORIES

- Installation and programming manual,
- Warranty Card
- Declaration of Conformity,
- 2 pcs M20x1.5 cable glands,
- pH/ORP electrode (as per order code, separately packed with user manual)
- DO sensor (as per order code, separately packed with user manual)
- SAP-300 display unit (optional)
- CD (EViewLight, DataScope softwares)

4. MAINTENANCE AND REPAIR

The **AnaCONT** series do not require maintenance on a regular basis, but the electrode (depending on the application) may need to be checked, cleaned, calibrated and replaced regularly.

Repairs during or after the warranty period are carried out exclusively at the Manufacturer's. Equipments sent back for repairs should be cleaned or neutralised (disinfected) by the User.

All sensors and electrodes including the NIVELCO recommended ones need proper storage, handling and calibration to have long life-time and give reliable measurement. Improper handling and lack of calibration will lead to unreliable measurement

4.1. STORAGE

DO sensors can be stored (under normal storage conditions) for a period of 12 month without shortening its lifecycle. The lifetime of pH and ORP electrodes is maximum one year (storage + usage). Prominent ships the electrodes hydrated in a well sealed container with a 3 mol/l KCl solution in it. As a result, the membrane remains wet and the electrode is in ready-to-use state. It is important to keep these containers as they are needed for storing the electrodes during calibration or in case of transportation. If for any reason the electrodes are taken out of the process they must be put back into the storage containers containing storage liquid.

Notes: Never let the membrane and the diaphragm desiccated. Do not leave the electrode on open air longer than 10 minutes. If the electrode is warm it can desiccate even within a shorter period of time!

4.2. PERIODIC SETTING, CALIBRATION AND VERIFICATION

The electrode is exposed to different stresses, dependent on the measured medium, its ORP and pH value and the medium temperature. That is why the electrode needs to be recalibrated (its accuracy needs to be checked) between certain time intervals depending on the application utilizations. The calibration intervals may vary from few days to several weeks (max. 8 weeks).

4.2.1. Periodic calibration of the pH electrode

The calibration has to be done minimum in two measuring points (using two different buffer solutions). The calibration points have to be selected so that the widest measuring range is covered. The common calibration points are 4.00pH and 10.00pH, 4.00pH and 7.00pH, 7.00pH and 10.00pH, or even more points for example 4.00pH, 7.00pH and 10.00pH.

Recommended solutions:

ORDER CODE	DENOMINATION
4vpuf4ph50mph	Buffer solution pH4 / 50 ml
4vpuf4ph250ph	Buffer solution pH4 / 250 ml
4vpuf4ph100ph	Buffer solution pH4 / 1 l
4vpuf7ph50mph	Buffer solution pH7 / 50 ml
4vpuf7ph250ph	Buffer solution pH7 / 250 ml
4vpuf7ph100ph	Buffer solution pH7 / 1 l
4vpuf10ph50ph	Buffer solution pH10 / 50 ml
4vpuf10ph25ph	Buffer solution pH10 / 250 ml
4vpuf10ph10ph	Buffer solution pH10 / 1 l
4vtarkcl 350ph	Storage solution KCl 3 mol / 50 ml
4vtarkcl 250ph	Storage solution KCl 3 mol / 250 ml
4vtarkcl 310ph	Storage solution KCl 3 mol / 1 l
4vtiszold 25ph	Cleaning solution / 250 ml

The given pH values refer to 25°C. The temperature dependency is given by the manufacturer, usually in a table on the label of the bottle.

The calibration procedure is described in chapter 6.5

4.2.2. Verification of the ORP electrode

The calibration can be done (for example) with a 465 mV buffer solution. After the electrode is rinsed with distilled water put the electrode into the buffer solution. The electrode should reach the correct measurement value in 30 seconds. If the measured value is less with more than (the acceptable) 20mV the electrode should be cleaned. If the electrode does not give the desired measurement after cleaning it has to be replaced

Recommended solutions:

ORDER CODE	DENOMINATION
4vpuf22050mor	Buffer solution ORP 220 mV / 50 ml
4vpuf220100or	Buffer solution ORP 220 mV / 1 l
4vpuf46550mor	Buffer solution ORP 465 mV / 50 ml
4vpuf465250or	Buffer solution ORP 465 mV / 250 ml
4vpuf465100or	Buffer solution ORP 465 mV / 1 l
4vtarkcl 350ph	Storage solution KCl 3 mol / 50 ml
4vtarkcl 250ph	Storage solution KCl 3 mol / 250 ml
4vtarkcl 310ph	Storage solution KCl 3 mol / 1 l
4vtiszold 25ph	Cleaning solution / 250 ml

The given (mV) values refer to 25°C. The temperature dependency is given by the manufacturer, usually in a table on the label of the bottle.

4.2.3. Periodic calibration of the DO sensor

The calibration has to be done minimum in two measuring points. Calibration points should be selected according to the required range to cover almost or fully. In every case it is necessary for the calibration: one solution which does not contain any oxygen – may be a neutral gas – for the zero standard calibration, and an other solution which has a known oxygen concentration for the full-scale standard calibration.

Zero calibration is necessary, because DO sensor gives output current when the measured medium does not contain any dissolved oxygen. This current is called residual-current. The required zero-standard is an aqueous solution of sodium-sulphite (Na_2SO_3) and cobalt(II)-chloride hexahydrate ($\text{CoCl}_2 \cdot 6\text{H}_2\text{O}$) prepared according to the followings. Oxygen-free nitrogen gas can be also used as zero-standard. The zero point calibration determines the offset of the calibration line.

Required items:

- 1 clean pot
- 1 mixer
- 1 dl distilled water
- 1g sodium-sulphite (Na_2SO_3)
- 1mg cobalt(II)-chloride hexahydrate –Analytical Reagent– ($\text{CoCl}_2 \cdot 6\text{H}_2\text{O}$)

Before the calibration pour the salts in the distilled water with continuous mixing.

For sensitivity calibration it is necessary a full-scale standard to determine the slope of the calibration line. Water solubility of oxygen at atmospheric pressure is well known dependent on temperature and pressure, so air-saturated water is a natural choice for full-scale standard. The air-saturated water is difficult to prepare and use. Usage of water-saturated air is a more general practice as a full-scale standard, because air-saturated water and water-saturated air are the same for the DO sensor. These are same standards, because the sensor is actually measuring the chemical potential of the oxygen. This chemical potential is a force driving through oxygen molecules from the sample through the membrane into the sensor. Output current of the sensor is proportional to the amount of oxygen driving through the membrane, so this current is determined by the chemical potential of the oxygen in the sample. The amount of oxygen is the same in air-saturated water and water-saturated air, so the chemical potential of the oxygen are also the same in both phases. Consequently the output current of the sensor is also the same in both cases.

Automatic calibration on air: The sensor should be simply hold in water-saturated air. The instrument measures the output current of the DO sensor, then store the measured value if stabilized and measures the temperature of the sample. It determines the saturation vapor pressure of the water from the temperature. Then it calculates the pressure of the dry air as the difference of atmospheric pressure and the saturation vapor pressure of the water. (Value of atmospheric pressure should be entered in the menu of the instrument as a parameter, default value is 1013mbar=101,3kPa) Considering the fact, that oxygen concentration of dry air is 20.95%, it calculates the partial pressure of the oxygen. Knowing the partial pressure of the oxygen, it calculates the amount of atmospheric dissolved oxygen in equilibrium at a current temperature using the Bunsen solubility coefficient. This calculated value is assigned to the stored output current of the sensor.

Usually it is has many difficulties to dismount the instrument or the sensor from the technologic process for the calibration. In case of this, the sensor can be calibrated to a measurement value of a portable laboratory instrument in the same technologic process. Before this type of calibration, the laboratory instrument (usually also using oxygen-permeable membrane amperometric sensor) should be calibrated in water-saturated air. The calibration procedure is described in 6.6.

4.3. MAINTENANCE OF THE pH AND ORP ELECTRODES

In this chapter you can find some recommendations regarding re-hydration, chemical cleaning and reactivation of the electrodes.

Disassembling the electrode

During this operation be careful not to expose the fragile electrode to mechanical (bending, squeezing, tensile) forces!

- Hold the electrode housing with one hand and the flare nut (right-threaded) with the other one and loosen it completely.
- Then detach carefully the electrode housing from the instrument housing.
- Loosen the electrode carefully using a socket-wrench (size 17) and screw it off completely.

Don't use a pipe- or a double-end wrench!

Put the electrode into the storage solution or perform the following steps below.

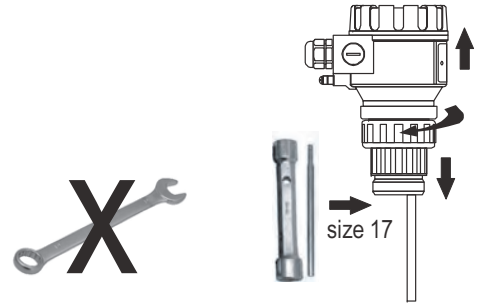

Re-hydration

If the electrode was desiccated due to incorrect use or storage it needs to be re-hydrated. This has to be done by soaking the electrode in 3mol/l KCl storage solution at 20°C for 24 hours. The process can be shortened to 6 hours if the KCl solution is at 60°C.

Note: long time desiccation or desiccation after measuring crystallizing mediums may have an irreversible effect on the electrode and thus the re-hydration may not be successful.

Chemical cleaning

The deposits and obstructions on the surface of the electrode's membrane and on the diaphragm have to be eliminated from time to time:

1. General deposits

- Rinse the electrode with warm water then dry up gently using a soft rag!
- Soak the electrode for 15 mins in 1.5mol/l (5%) hydrochloric acid (HCl)!
- Rinse the electrode again with warm water then dry up gently using a soft swab!
- Soak the electrode for 1 hour in 3mol/l KCl solution then perform the calibration procedure!

2. Non-organic deposits

- Rinse the electrode with warm water then dry up gently using a soft rag!
- Soak the electrode for 15 mins in 0.1 mol/l EDTA (ethylenediaminetetraacetic acid) solution!
- Rinse the electrode again with warm water then dry up gently using a soft rag!
- Soak the electrode for 1 hour in 3mol/l KCl solution then perform the calibration procedure!

3. Protein deposits

- Rinse the electrode with warm water then dry up gently using a soft rag!
- Soak the electrode for 15 mins in 0.5 mol/l hydrochloric acid (HCl) or in 0.1 mol/l HCl and 0.1% pepsin mixture!
- Rinse the electrode again with warm water then dry up gently using a soft rag!
- Soak the electrode for 1 hour in 3mol/l KCl solution then perform the calibration procedure!

4. Silver sulphide deposits

- Rinse the electrode with warm water then dry up gently using a soft rag!
- Soak the electrode for 15 mins in 0.1 mol/l thiourea and 1.5 mol/l (5 %) hydrochloric acid (HCl)!
- Rinse the electrode again with warm water then dry up gently using a soft rag!
- Soak the electrode for 1 hour in 3mol/l KCl solution then perform the calibration procedure!

Note: when deposits are hard to remove try using hydrogen peroxide or sodium hypochlorite solutions.

Reactivation

Regeneration of the glass membrane:

The physical or chemical damage of the glass membrane slows down the operation of the electrode. The reactivation of the membrane helps restoring the normal operation of the electrode.

- Immerse ONLY the spherical part of the glass electrode into ammonium bifluoride with 10% concentration for 60 seconds then immediately into 50-50% mixture of undiluted HCl and water for 10 seconds. This will neutralize the strong base!
- Soak the electrode for 12 hours in 3 mol/l hydrochloric acid (HCl)!
- Rinse the electrode with water then dry up gently using a soft rag!
- Soak the electrode for 1 hour in 3 mol/l KCl solution then perform the calibration procedure!

Reassembling the electrode

During this operation be careful not to expose the fragile electrode to mechanical (bending, squeezing, tensile) forces!

- Insert the electrode to its place carefully, screw it in with your hand and then with a socket-wrench (size 17) carefully, until it reaches the level of the connector of the temperature sensor ($9.5\text{mm}_{-0.5}^{+0}$, see figure). **Don't use a pipe-wrench or a double-end wrench!**
- Assemble the instrument housing and the electrode housing then fasten the flare nut with your hand. Pay attention to the encasement of the anti-rotation guides.

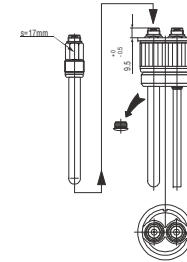

4.4. MAINTENANCE OF THE DO SENSOR

During this operation be careful not to expose the fragile electrode to mechanical forces! Do not scratch, finger or touch the membrane of the sensor!

- Dismount the instrument from the technology process.
- While holding the instrument in one hand rinse the membrane of the sensor with clean water. If necessary some detergents could be used.
- Dry up the sensor gently using a soft rag.

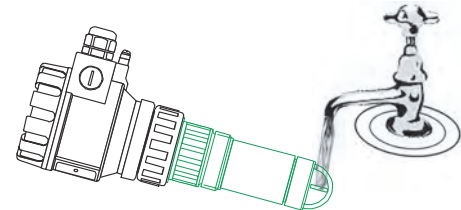

4.5. SOFTWARE UPDATE

Based on the observation and needs of our customers NIVELCO constantly improves the operating software of the device. The software can be upgraded with the help of the ELink (USB) communication adapter plugged into the socket of the SAP-300 display. For software updates and for more information about software updates please contact NIVELCO.

5. INSTALLATION

5.1. MOUNTING

- When choosing the installation place please ensure proper space for later calibrations, verification or maintenance service. (see placement on page 32.)
- **Make sure that the transmitter is protected against overheating that can be caused by direct sunshine.**
- Assemble the electrode with the instrument prior to the installation.
- It is advised to check the operation of the instrument prior to the installation in the control room.
- If factory settings need to be modified do it according to the **Programming Description**.
- The process connection should be selected according to the type to be installed.

ATTENTION!

When mounting or dismantling the instrument, avoid exposing the electrodes, DO sensors and temperature sensors to mechanical impacts because these can cause malfunctioning of the unit. The unit should not be loosened if the process is under pressure, in this case user should take care of depressurization first!

5.1.1. Installation of pH and ORP electrodes

Prior to mounting into the process the instrument should be put into operation-ready state. For this the user has to insert the electrode (packed separately) into the instrument as described below:

During this operation be careful not to expose the fragile electrode to mechanical (bending, squeezing, tensile) forces!

The housing of the instrument can be disassembled as described in chapter 4.3.

- Remove the plug in the electrode housing from the connector of the electrode.
- Open the box and screw the electrode off the container.
- Insert the electrode to its place carefully, screw in with your hand and using a socket-wrench (size 17) until it reaches the level of the connector of the temperature sensor ($9.5mm_{-0.5}^{+0}$).
- **Don't use a pipe-wrench or a double-end wrench!**

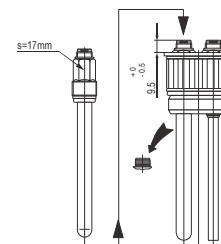

Assemble the instrument as described in Chapter 4.3.

If the instrument is not installed immediately into the process the electrode should be put into storage solution to keep it wet.

5.1.2. Installation of DO sensor

Prior to mounting into the process the instrument should be put into operation-ready state. For this the user has to insert the DO sensor (packed separately) into the instrument as described below:

During this operation be careful not to expose the fragile DO sensor to mechanical (bending, squeezing, tensile) forces!

- Remove the threaded protector- basket and the sponge-disc protector of the contacts.
- Unpack the DO sensor and place it into a flat surface, downward with the plastic cap. **Do not wipe the out the silicone grease from the back of the membrane! Silicone grease protect the contacts against short-circuit, even if water is infiltrated.**
- With one hand hold the instrument upwards with its sensor, with other hand remove the (right-threaded) protector- basket of the sensor.
- Place the sensor into the instrument with its cap that the pins of the sensor-nest can fit into the holes in the rear side of the sensor.
- Remove the cap from the sensor and replace the protector- basket of the sensor.

TEMPERATURE

As it is shown in the diagram below – there may be a drop in the pressure-resistance according to the changes of the medium temperature, - which, in any case, should be considered, prior to the installation of the instrument into the technology process:

Depending on the location of the installation the instrument should be protected against any heat source or direct sunlight to avoid higher temperatures than specified!

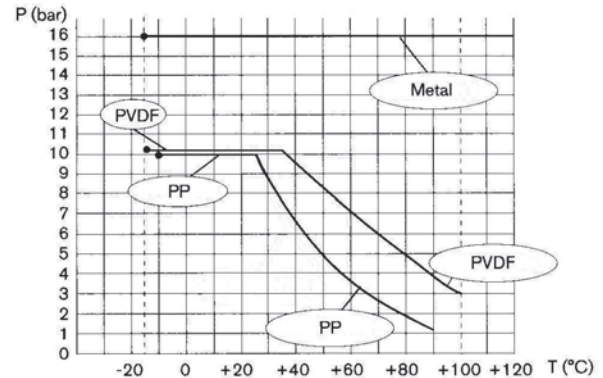

PLACEMENT

The instrument should be mounted within a max. 45° angle, compared to vertical position. Types mounted with 4xphek112seph / 4xorrhek1seor electrode may be positioned horizontally as well!

If the unit is installed using a fitting piece the user has to assure that before and after the fitting piece there is a straight pipe with the appropriate length to minimize sedimentation and turbulency. The influent section has to have min. 10xDN length while the effluent section has to have min. 3xDN length.

It is advised to create a by-pass line so during the service of the instrument the electrode is kept wet or a calibration can be done without stopping the process.

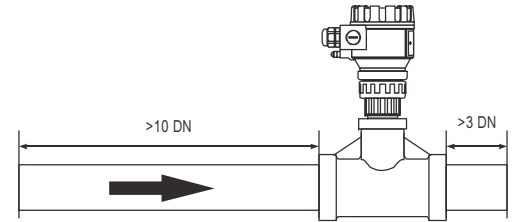

LIQUID CONTINUITY

Near the electrode (sensor), the pipeline should always be filled with liquid:

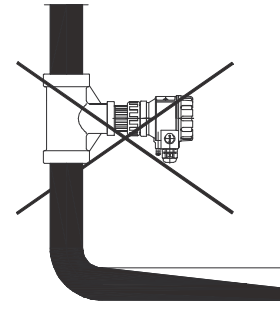
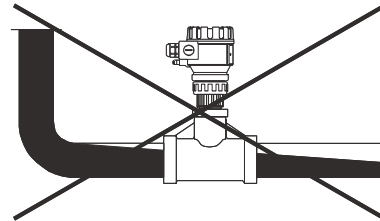
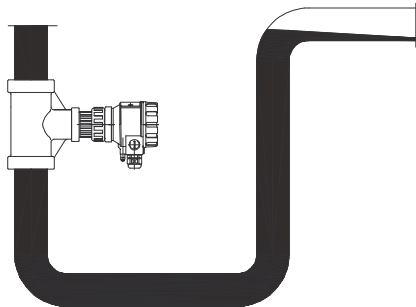
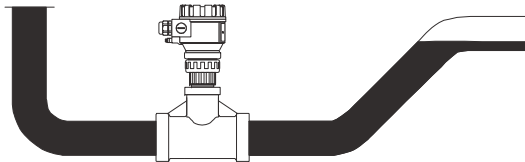

BUBBLE, FOAM

Near the electrode (sensor), liquid in the pipeline should be free of bubbles or foam.

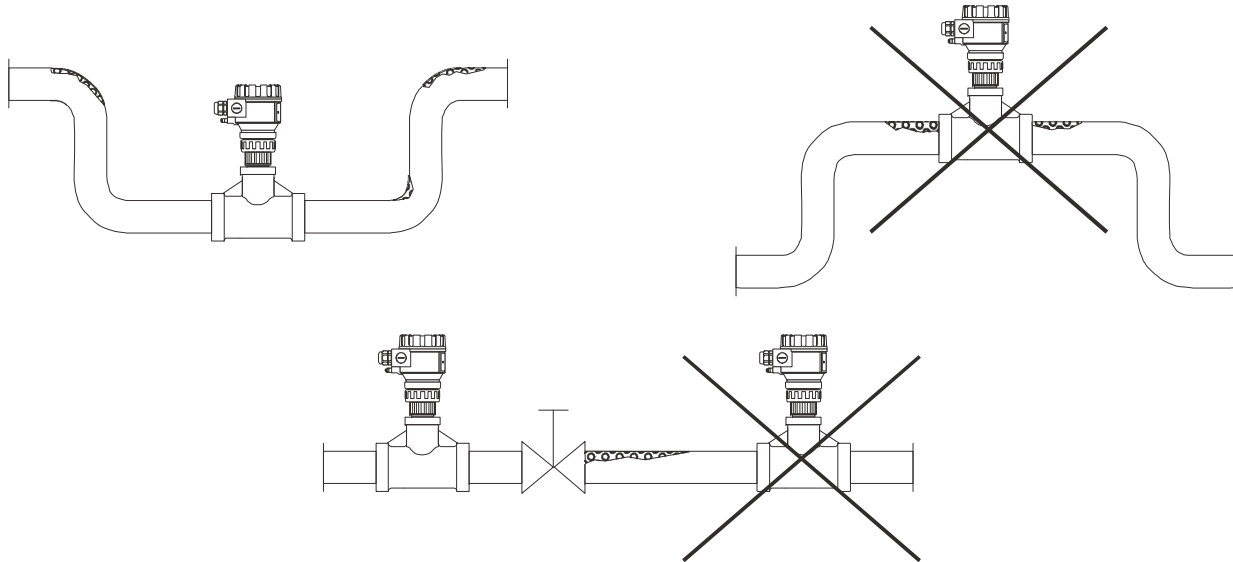

Installation of the threaded models

- Screw the unit into its place and tighten by hand. Don't use any tool!
- After tightening, the enclosure can be rotated to the proper position. (Safety bolt prevents rotation more than 350°).

5.1.3. Special application possibilities of the Integrated type instruments

Integrated type instruments can be installed in the same place with the medium to be measured. In this case of application, the maximal process pressure can not exceed 0.5 bar!

5.1.4. Installing extension units

When mounting the LA□-□□□-0 extension units, follow the mounting sequence shown on the figures. Observe the integrity of the sealing ring and the correct connection of the electrical connection cables (TEMP wire).

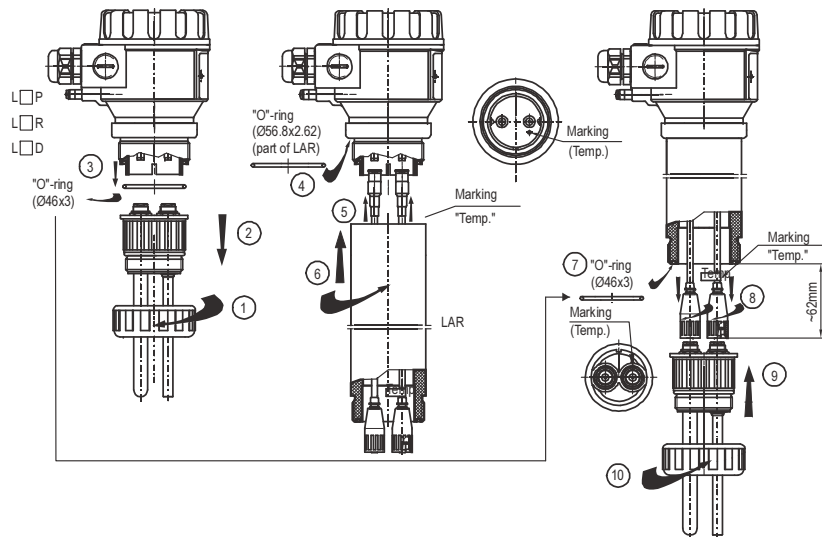

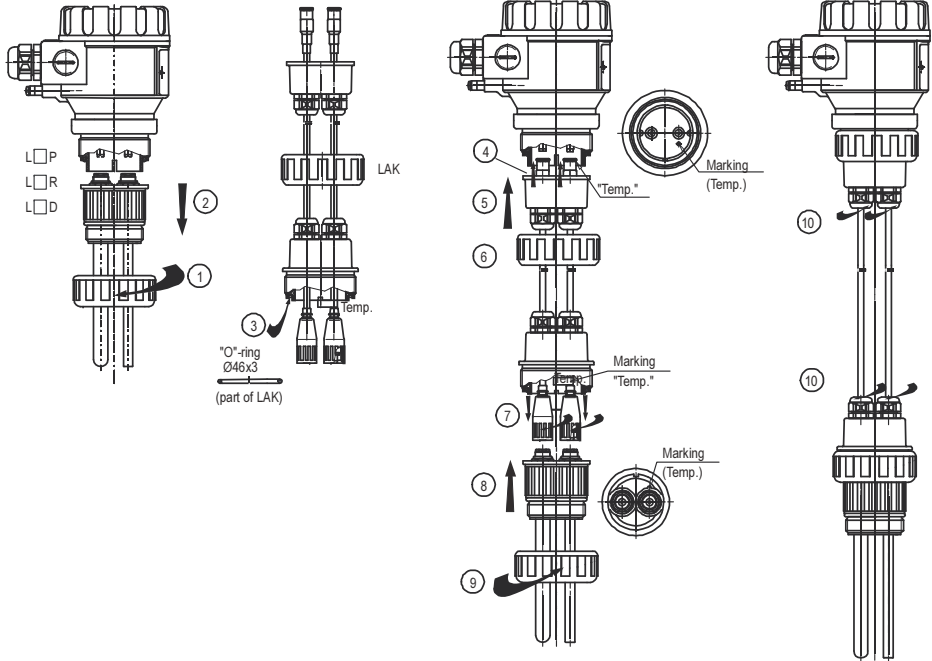

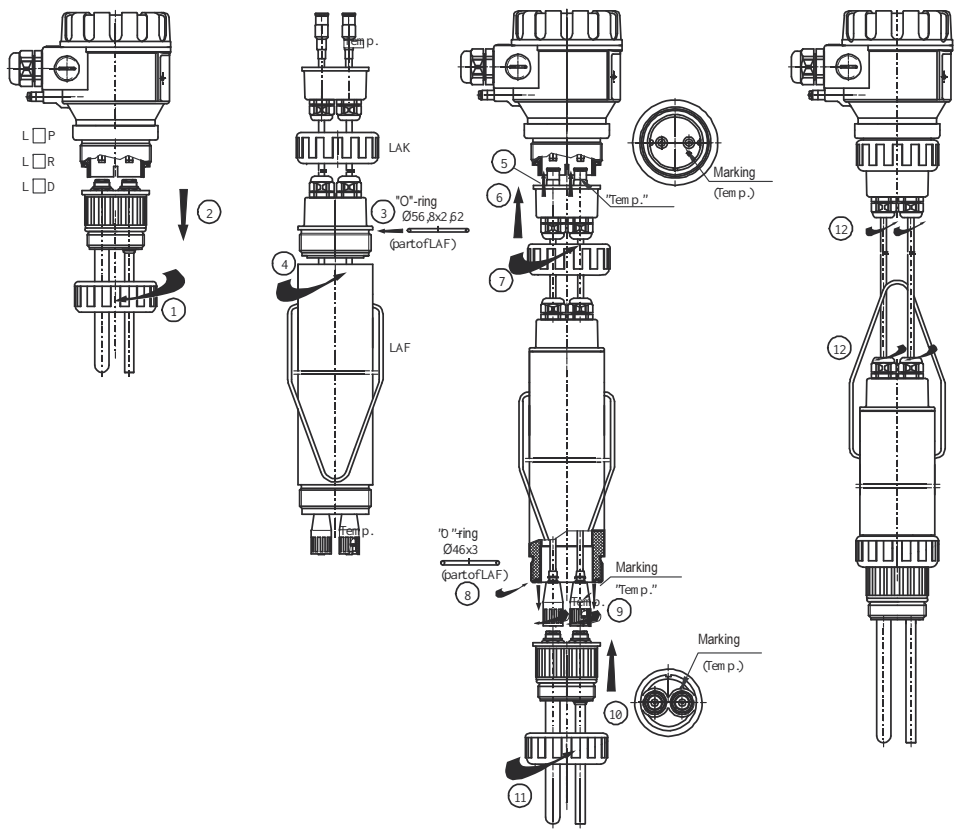

5.2. WIRING

The instrument operates from 12.5 ... 36 V galvanic isolated and not grounded DC power supply in two wire system. (For Ex version: 12.5 ... 30 V DC!) Sum of the resistance of the equipped instruments, between the transmitter and the power supply, mainly depends on the supply voltage of power supply applied, and the overall resistance value cannot exceed 1200 ohms. In case of using HART interface – to achieve proper communication between the transmitter's interface and the power-supply – a minimal 250 ohms resistance should be maintained within the network.

5.2.1. Wiring of Compact instruments

The instrument should be wired with shielded cable led through the cable gland. The wiring of cables can be done after removing the cover of the instrument and the SAP display unit.

- Make sure that the power supply is turned off at the source.
- After removal of the cover of the housing and taking the display module (if any) out, the wiring cables can be connected. (Recommended cable: shielded, two-wire, with 0.5 ... 1.5 mm² cross section. Connect shielding to grounding by the inner or outer grounding screw first.
- Switch on the unit. After switching of the unit, necessary programming can be done.
- After the wiring, adjustment and programming, check proper sealing and close the cover carefully.

IMPORTANT: - The housing of the transmitter should be grounded to the EPH network. Resistance of the EPH network should be $R \leq 2$ ohm measured from the neutral. Shielding of the cable should be grounded at the control room side to the EP network. To avoid disturbing noises, keep away of closeness to high-voltage cables. Especially critical can be the inductive couplings of harmonics (which are present at frequency converter control) because even cable shielding does not supply effective protection against these cases.

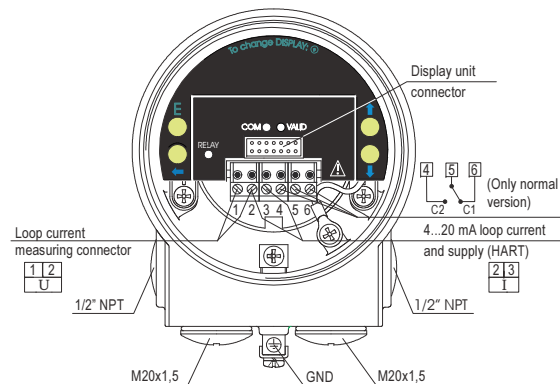

The instrument may be damaged by electrostatic discharge (ESD) via its terminal, thus apply the precautions commonly used to avoid electrostatic discharge e.g. by touching a properly grounded point before removing the cover of the enclosure.

5.2.2. Wiring of Integrated instruments

The instrument can be connected directly to the suitable power supply unit. When extending the cable, a junction box is needed to use for this purpose. Shielding should be connected with the shield of the extending cable and should be grounded at the signal processing device.

- Make sure that the power supply is turned off at the source.
- (Recommended cable: shielded cable with 6 x 0.5 mm² or greater cross section).
- Turn on the power supply. After switching of the unit, necessary programming can be done.

Colour codes of the wires:

Green	– C1 relay output	White	– I One point (polarity-independent) of loop current, power supply and HART
Yellow	– CC relay output	Brown	– I Other point (polarity-independent) of loop current, power supply and HART
Grey	– C2 relay output	Black	– GND Grounding and shielding point

IMPORTANT: The shielding of the transmitter should be grounded at the control room side to the EPH network. Resistance of the EPH network should be $R \leq 2$ ohm measured from the neutral. To avoid disturbing noises, keep away of closeness to high-voltage cables. Especially critical can be the inductive couplings of harmonics (which are present at frequency converter control) because even cable shielding does not supply effective protection against these cases.

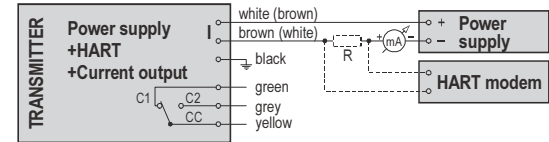
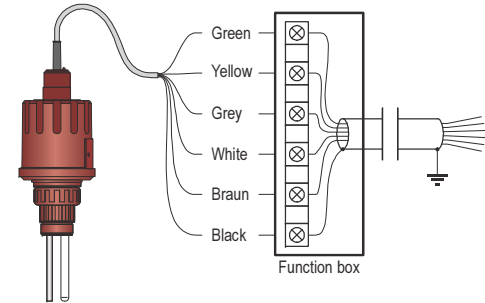

5.3. LOOP CURRENT CHECKING WITH HAND INSTRUMENT

After removing the cover and lifting the Display Module, the actual loop current can be measured with an accuracy of ~ 5% by connecting a voltmeter (in the range of 200 mV) to the points indicated on the drawing above.

5.4. CONDITIONS OF EX APPLICATION





- Intrinsically safe units with Ex ia IIB marking can only be used in certified intrinsically safe loops with the previously given technical data. (see values in special data for Ex approved models under Point 3).
- The size of the macrolon window of intrinsical safe equipment with metallic enclosure exceeds the limit, thus the devices must be protected against electrostatic charges.
- Equipment with plastic housing are susceptible to electrostatic charges, thus the deivces must be protected against electrostatic charges.
- The aluminium content of equipment with metallic enclosure exceeds the limit, the devices must be protected against impact and friction effects.
- Devices should be grounded by connecting their grounding screws to the equipotential system.

6. PROGRAMMING

The AnaCONT instruments can be programmed with the SAP-300 display unit.

Without SAP-300 the following LEDs can be seen:

- **RELAY** Indicates the energised state of the relay (C2 closed, C1 open)
- **VALID** Indicates the measuring capability of the unit. If lit, the input signal is stabilised. If blinking, the input signal is changing.
- **COM** Indicates digital (HART) communication. During Remote programming LEDs are continuously illuminated.

When SAP-300 display is present, LEDs are not visible; functions are taken over by the display. In default state SAP display shows the primary measured value (which the output current is calculated from). Programming is supported by a text-based menu. Navigation is done by using the  /  /  /  buttons.

The instrument can operate without the SAP-300 module as well. Programming can be done only by using SAP-300 display module locally or by HART (REMOTE PROGRAMMING) communication system remotely.



6.1. THE SAP-300 DISPLAY UNIT

The SAP-300 is a 64x128 dot-matrix LCD display which can be plugged into the transmitter. (Universal – usable in other NIVELCO devices as well – provided that the system software supports SAP-300.)

Warning!

The SAP-300 module is based on LCD technology, so please make sure it is not exposed to permanent heat or direct sunlight, in order to avoid damage of the display unit. If the instrument cannot be protected against direct sunlight or high temperature that is beyond the standard operating temperature range of the SAP-300, please do not leave the SAP display in the instrument.



6.2. MEASURING WITH THE SAP-300 DISPLAY UNIT

Elements of the display:

1. Primary value (PV), in a dimension depended on the type of the instrument
2. **SENSOR VOLTAGE** – informative data in case of pH measurement
3. Trend direction arrows. The empty triangle shows when the measured value is small, the filled triangle shows large-scale change. If none of the arrows are shown the measured value is constant.
4. Measured value in relation to measurement range (Sensor range) in a bargraph.
5. Temperature is shown for temperature compensation (measured by internal sensor).

After the dimension, the temperature compensation mode is indicated by inverse inscription:

Any possible errors during measurement are shown in the lower part of the display.

M

Manual mode (see 6.4.1.3)

SIM

Temperature simulation active (see 6.4.5.8)

E!

Temperature sensor error. In this case the instrument will compensate to 25 °C.

6. Indication of primary value simulation. In this case the display and output will show the values of the simulation and not the measured value.

7. Measured value normalized to 25°C, 760Hgmm and Salinity=0 – informative data (only for DO transmitters)

8. Oxygen saturation (only for DO transmitters)

During active simulation the critical measurement errors will be displayed to give information to the user.

pH measurement

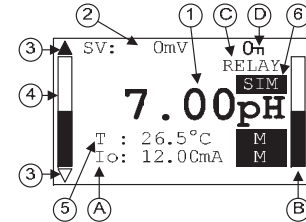

ORP measurement

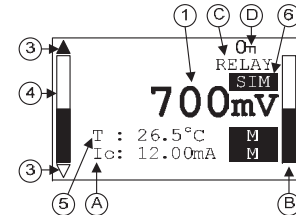

DO measurement

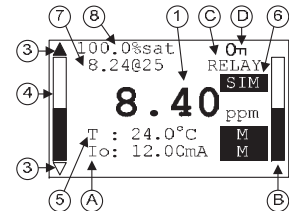

A. Calculated value of the output current. After the dimension, the mode of current output is indicated by inverse inscription:

M

Manual mode (see **6.4.2.1**)

H

HART address is not 0, so output current has become overwritten to 4mA (see **6.4.2.1**)

E!

Analogue transmission reacts to a programmed failure condition if an upper or lower fault current is programmed. (see **6.4.2.4**)

B. Output range (4...20mA) indicated in a bargraph.

C. Relay state indication: if deenergized – C1 closed, C2 open, there is no indication. If RELAY message is visible, the relay is energised – C2 closed, C1 open.

D. Indication of Menu Lock:

- If key symbol is visible, the unit is protected with a password. When entering the menu, the instrument asks for the correct password.
- If REM message is visible, the instrument is in remote programming mode and the menu cannot be accessed.

Errors occurred during the measurement can be seen at the bottom line of the display.

Information displays:

Press \odot button to cycle between the information displays.

1. The general information display (DEV. INFO): overall running time (OV. RUN TIME), run time after power on (RUN TIME), type of interface (INTERFACE), relay (RELAY) and logger (LOGGER) indication.

2. Sensor information: time passed after last sensor change, slope and offset after sensor change, time passed after last calibration, slope and offset at last calibration, minimum / maximum temperature of the sensor.

In case of DO measurement in addition to these: atmospheric pressure (PRESSURE) and salinity (SALINITY).

3. Relay information: number of switchings, total energised time (C2 closed) (only if there is a relay in the unit).

The informative display switches back to main screen after 30 seconds.

By pressing the \uparrow button the user can get back to main screen at any time.

Pressing the E button in any of the displays the user can enter to menu. After exiting the menu always the main screen will be shown.

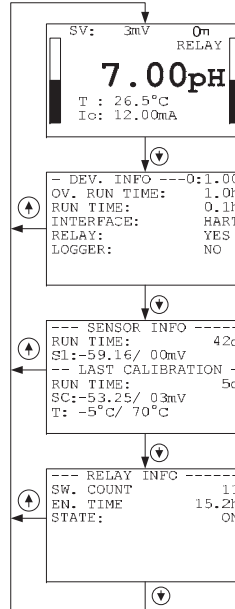

Information display of pH measurement

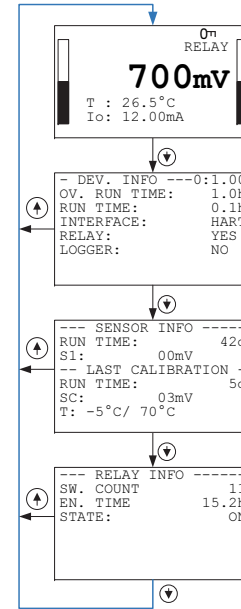

Information display of ORP measurement

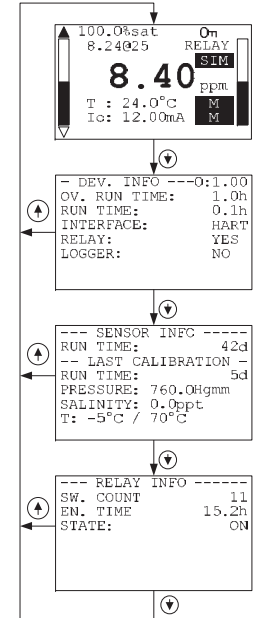

Information display of DO measurement

6.3. PROGRAMMING WITH THE SAP-300 DISPLAY MODULE

When entering the menu the instrument makes a copy of the actual parameters, all changes are done to this duplicated parameter set. During programming the instrument keeps measuring and transmitting with the current (and intact) parameter set. After exiting the menu the instrument replaces the original parameters with the new parameter set and will measure according to the new parameters. This means that the change of the parameters does not become immediately effective when pressing the E button!

Entering the menu can be done by pressing the E button while exiting the menu can be done by pressing the \leftarrow button.

If the instrument is left in programming mode after 30 mins it will automatically return to measuring mode. If the SAP display is removed during programming the instrument immediately returns to measuring mode.

As programming with SAP-300 (manual programming) and HART (remote mode) programming is not possible at the same time use only one programming method at a time. Measured values can be read out through HART at any time

6.3.1. Components of the programming interface

The parameters of the instrument are grouped according to their functions. The programming interface consists of lists, dialog windows, edit windows and report windows.

Lists

Navigation between the lines of a list can be done by pressing \uparrow / \downarrow buttons. Pressing the E button activates a list item. Selected list item is marked with inverse colour. Exit from a list by pressing the \leftarrow button.

Menu list

Menu list is a specialized list. Its characteristic is that upon selecting a list item we directly get into another list, and these lists are opening from each other in different levels.

The menu header (1) helps to navigate.

Entering the menu can be done by pressing the E button. Navigation between the menu items can be done by pressing the \uparrow / \downarrow buttons. Enter to the selected menu by pressing the E button. The selected list item is marked with inverse colour.

Exit from a submenu with \leftarrow button. Pressing the \leftarrow button in the main menu will exit programming mode and the instrument will return to measuring mode.

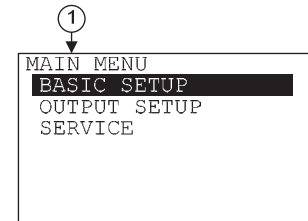

Dialog window

The system sends messages or warnings using dialog windows. These usually can be acknowledged by pressing the \leftarrow button or the user can choose between two options (usually YES or NO) by pressing \leftarrow / \downarrow buttons. In some cases to correct an error one of the parameters has to be changed

Edit window

An edit window is used for modifying a numeric parameter value. The selected character can be changed using the \leftarrow / \downarrow buttons. The cursor can be moved to left, using the \leftarrow button. The direction of the cursor movement through the digits is right to left. Changed value can be validated by pressing the E button. The software checks if the entered value is appropriate, exiting the edit window is only possible after entering a correct value. If the entered value is uninterpretable the software sends an error message in the bottom line (1) of the display. The display gives the same error message, independently of the measured value and the measurement principle.

Edit window – button combinations

In the edit window the following button combinations are available:

1. Recalling the parameters to the state before editing (\leftarrow + \uparrow , pressed for 3 secs);
2. Recalling default parameters (\leftarrow + \downarrow , pressed for 3 secs);
3. Inserting (currently) measured value to the edit window (\uparrow + \downarrow , pressed for 3 secs)
Only for certain parameters!

6.3.2. Menu structure

Main menu

BASIC SETUP	Parameter group of the basic measurement parameters
OUTPUT SETUP	Parameter group of the output parameters
SERVICE	Service functions, calibration, test and simulation

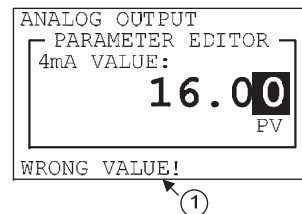
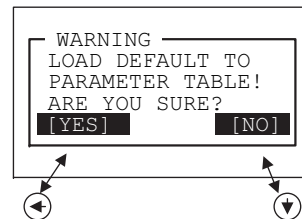

PV: primary Value

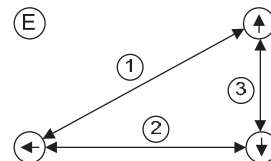

6.4. PROGRAMMABLE FEATURES DESCRIPTION

6.4.1. Basic measurement settings

6.4.1.1 Measuring unit (Only for DO measurement)

- Parameter: P02: b
Menu path: BASIC SETUP / MEASURING UNIT
Description: Dimension of PV: primary value.
- ppm
 - mg/l
 - %sat

Primary values are the same in case of displaying ppm and mg/l, only displayed and transmitted dimension changes. Large number on the screen follows the dimension of ppm and mg/l in the setting of ppm and mg/l.

In case of choosing %sat, large numbered primary value indicates the oxygen saturation.

Default value:
ppm

6.4.1.2 Damping time

- Parameter: P20
Menu path: BASIC SETUP / DAMPING TIME
Description: Damping time is used to damp the unwanted fluctuations of the output and display.
If the measured value changes rapidly the new value will settle with 1% accuracy after this set time

Default value:		
pH measurement	ORP measurement	DO measurement
2 sec	2 sec	2 sec

6.4.1.3 Temperature compensation mode

- Parameter: P06: a
Menu path: BASIC SETUP / TEMP. COMPENSATION / MODE
Description: Mode of the temperature compensation
- AUTO Compensation is done with the value measured by the temp. sensor.
 - MANUAL Compensation is done with a predefined temperature value (see 6.4.1.5)
 - OFF No compensation

Default value:
AUTO

6.4.1.4 Temperature compensation unit

Parameter: P02: a
Menu path: BASIC SETUP / TEMP. COMPENSATION / UNIT
Description: Dimension of the temperature measurement

- °C
- °F

Default value:
°C

6.4.1.5 Temperature compensation fixed value

Parameter: P07
Menu path: BASIC SETUP / TEMP. COMPENSATION / MANUAL VALUE
Description: Value of the manual temperature compensation (see 6.4.1.3)

Default value:
25 °C

6.4.1.6 Salinity correction value (Only for DO measurement)

Parameter: P23
Menu path: BASIC SETUP / SALTINITY CORRECTION / MANUAL VALUE
Description: Value of the salinity correction in ppt (parts per thousand)

Default value:
0 ppt

6.4.1.7 Pressure correction unit (Only for DO measurement)

Parameter: P02: c
Menu path: BASIC SETUP / PRESSURE CORRECTION / UNIT
Description: Dimension of the atmospheric pressure correction

- Hgmm Compensation is performed by the measured value of the temperature sensor
- bar Compensation is performed by a fix given temperature value.
- kPa Compensation is off

Measurement unit is required to be selected first and value should be entered after this.

Default value:
Hgmm

6.4.1.8 Pressure correction value (Only for DO measurement)

Parameter: P22
Menu path: BASIC SETUP / PRESSURE CORRECTION / MANUAL VALUE
Description: Value of the atmospheric pressure correction

Measurement unit is required to be selected first and value should be entered after this.

Default value:
760 Hgmm

6.4.2. Analogue output

6.4.2.1 Output current mode

Parameter: P12: b

Menu path: OUTPUT SETUP / ANALOG OUTPUT / CURRENT MODE

Description: Transmission mode of the current output [AUTO, MANUAL]

- AUTO The output current is calculated from the measured value, output is active.
- MANUAL The output current is fixed at a constant (set) value (see 6.4.2.5). In this mode the setting of the error current (see 6.4.2.4) is irrelevant. The set (current) value overwrites the 4mA output of HART multidrop mode!

Default value:
AUTO

6.4.2.2 Output current value 4mA

Parameter: P10

Menu path: OUTPUT SETUP / ANALOG OUTPUT / 4mA VALUE

Description: Measured value assigned to 4mA

Default value:		
pH measurement	ORP measurement	DO measurement
0 pH	- 1000 mV	0 ppm

6.4.2.3 Output current value 20 mA

Parameter: P11

Menu path: OUTPUT SETUP / ANALOG OUTPUT / 20mA VALUE

Description: Measured value assigned to 20mA

Default value:		
pH measurement	ORP measurement	DO measurement
14 pH	1000 mV	8.24 ppm

6.4.2.4 Output current error mode

Parameter: P12: a

Menu path: OUTPUT SETUP / ANALOG OUTPUT / ERROR MODE

Description: Error indication by the current output

- HOLD Error indication has no effect on the output current.
- 3.8 mA Error indication: the output current gets 3.8mA.
- 22 mA Error indication: the output current gets 22mA

Attention! Also see chapter 6.4.2.1!

Default value:
HOLD

6.4.2.5 Fixed output current

Parameter: P08
 Menu path: OUTPUT SETUP / ANALOG OUTPUT / MANUAL VALUE
 Description: Parameter for setting the fixed output current
 Values between 3.8 and 20.5 can be entered. The output current will be set to the entered value and analogue transmission will be suspended. . (see 6.4.2.1)
 The set (current) value overwrites the 4mA output of HART multidrop mode!

Default value:
4 mA

6.4.3. Relay output

6.4.3.1 Relay output mode

Parameter: P13: a
 Menu path: OUTPUT SETUP / RELAY OUTPUT / MODE
 Description: Relay operating mode:

- OFF Relay off (C1 closed, C2 open)
- PH/ORP/DO Relay operation assigned to the measured pH / ORP / DO value
- TEMP Relay operation assigned to the measured temperature
- ON ERROR Relay operates on critical errors

Default value:
OFF

6.4.3.2 Relay output functions

Parameter: P13: b
 Menu path: OUTPUT SETUP / RELAY OUTPUT / FUNCTION
 Description: Relay operation functions:
 Differential control. (ex.: for controlling tasks)

HYSTERESIS If the two switching values are close to each other it will operate as a limit switch.

WINDOW Window comparator mode (ex.: for monitoring a range).
 $H1=H2=0.05\text{pH}$ or $0.05\text{ }^{\circ}\text{C}$

Default value:
HYSTERESIS

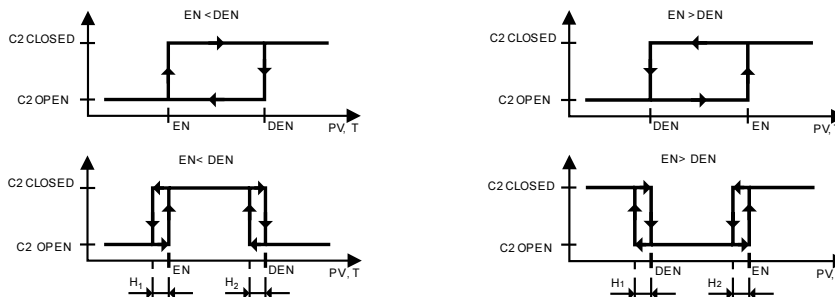

PV: Primary Value – pH measurement: pH, ORP measurement: mV, DO measurement: ppm

6.4.3.3 Relay output energised value

Parameter: P14
Menu path: OUTPUT SETUP / RELAY OUTPUT / ENERGIZED VALUE (EN)
Description: Value of the relay when it will become energised (C1 open, C2 closed)

Default value:		
pH measurement	ORP measurement	DO measurement
0 pH	- 1000 mV	0 ppm

6.4.3.4 Relay output de-energised value

Parameter: P15
Menu path: OUTPUT SETUP / RELAY OUTPUT / DEENERGIZED VALUE (DEN)
Description: Value of the relay when it become deenergised at (C1 closed, C2 open)

Default value:		
pH measurement	ORP measurement	DO measurement
14 pH	1000 mV	8.24 ppm

6.4.3.5 Relay switching (ON/OFF) delay

Parameter: P16
Menu path: OUTPUT SETUP / RELAY OUTPUT / DELAY
Description: Delay time of the relay switching On or Off (0 – 99 sec)

Default value:
0 sec

6.4.3.6 Relay inverted operation

Parameter: P13: c
Menu path: OUTPUT SETUP / RELAY OUTPUT / INVERTING
Description: Relay operation

- NO Normal operation
- YES Inverted operation

Default value:
NO

6.4.4. Digital output

6.4.4.1 HART polling address

Parameter: P19

Menu path: OUTPUT SETUP / SERIAL OUTPUT / ADDRESS

Description: HART polling address (only HART capable types)

The polling address can be set between 0 and 15. For a single instrument the polling address is 0 and the output is 4...20mA (analogue output). If multiple units are used in HART Multidrop mode (max. 15pcs) the polling addresses should differ from 0 (1-15), in this case the output current will be fixed at 4mA. The fixed 4mA output can be overwritten as described in chapter 6.4.2.5.

Default value:
0

6.4.5. Service functions

6.4.5.1 Security codes

User security code

Parameter: -

Menu path: SERVICE / SECURITY / USER LOCK

Description: Setting or unlocking the user security code.

The instrument can be protected against unauthorized programming with a 4 digit PIN (Personal Identification Number) code. If either of the digits differs from 0 the code is active. If zero is specified, then the secret code has been deleted!
In case of Active code, this code is requested at menu entry.

Default value:
0

Service code

Parameter: -

Menu path: SERVICE / SECURITY / SERVICE LOCK

Description: Setting of the service code (only for trained personnel)!

6.4.5.2 Loop test

Parameter: P80

Menu path: SERVICE/OUTPUT TEST / ANALOG OUTPUT

Description: Loop current test (mA)

Values between 3.9 and 20.5 can be entered. The output current will be set to the entered value. The measured current on the output should be equal to the set value.



In test mode a dialog window warns the user of the fixed output current until the user exits the warning message window.

Exiting can be done by pressing the  button.

6.4.5.3 Relay output test

Parameter: P81

Menu path: OUTPUT SETUP / TEST / RELAY OUTPUT

Description: Used for the testing of the relay output. Pressing the  and  buttons the relay will change state.

When in this menu point the programmed relay operation is not taken into consideration.

- DEENERGIZED Relay is de-energised
- ENERGIZED Relay is energised

6.4.5.4 pH Sensor calibration

Parameter: -

Menu path: SERVICE / SENSOR CALIBRATION

Description: Calibration of the pH sensor (electrode) (see 6.5).

- VIEW/EDIT TABLE Table overview
- ADD ITEM Addition of a calibration point
- DELETE ITEM Deletion of a calibration point
- RESET TO DEFAULT Resets the calibration table to default
- RESET TIMER Resets the inner timer of the pH electrode life-time monitoring routine. This timer is **NOT a real-time clock**. It only counts when the instrument is powered. Its value is saved in a non-volatile memory

6.4.5.5 ORP Sensor calibration

- Parameter: -
Menu path: SERVICE / SENSOR CALIBRATION
Description: Calibration of the ORP sensor.
- SET ZERO POINT Setting the zero point of the sensor
1. Measured value (without setting).
 2. Real (measured) value at the zero point of the sensor

Use a 0 mV buffer solution. Dip the sensor into the buffer solution and wait until the measured value (1) becomes stabilised! Set the uncalibrated measured value (1) in the edit field using the \leftarrow , \rightarrow and \downarrow buttons. By pressing \leftarrow and \downarrow simultaneously the measured value can be entered to the edit field.

Entering the SERVICE / SENSOR CALIBRATION menu the instrument will display a warning message that the user is about to change critical parameters of the measurement system. The user can enter the menu by pressing the \leftarrow (OK) button or exit to the previous menu by pressing the \downarrow (NO) button. In the next dialogue the software asks the user if the calibration of the sensor is the „first” calibration (after a new sensor is installed) or not. Select OK or NO buttons. If OK button is selected the stored informational parameters of the previous sensor are reset to default values. Select \downarrow (NO) button if it is not a „first” setting.

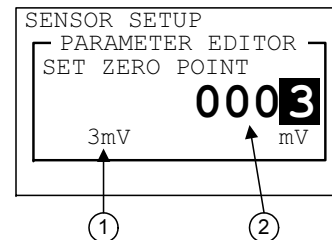

6.4.5.6 DO Sensor calibration

- Parameter: -
Menu path: SERVICE / SENSOR CALIBRATION
Description: Calibration of the DO sensor. Calibration process is described at chapter 6.6.
Calibration shall be performed in air or referential liquid, sanity is zero in both cases.
- CAL. IN AIR (SPAN) Calibration of saturated value (100%sat) with sensor in air (8.24ppm / [25°C, 760Hgmm])
 - CAL. IN ZERO SOL. Calibration of the Zero point in referential liquid.
 - CAL. IN SPAN SOL. Calibration of the saturated value (100%sat).
 - RESET TO DEFAULT Resets the calibration table to default
 - RESET TIMER Resets the inner timer of the pH electrode life-time monitoring routine.

This timer is **NOT** a real-time clock! It only counts when the instrument is powered. Its value is saved in a non-volatile memory

6.4.5.7 Simulation

This function helps the user to check the outputs and the additional processing instruments connected to the output. (Irrespectively of the instruments)
To start simulation the instrument must return to Measuring mode.

Simulation mode

Parameter: P84: a

Menu path: SERVICE / SIMULATION / MODE

Default value:
OFF

Description: Simulation mode:

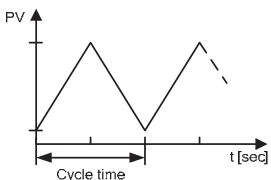
OFF	No simulation	
FIX VALUE	Its value is set according to the lower range value of pH / ORP simulation	
TRIANGLE WAVE	The simulated value changes linearly between the set low and high values with an adjustable cycle time.	 <p>PV: Primary Value</p>
SQUARE WAVE	The simulated value jumps between the set low and high values with an adjustable cycle time.	

Simulation cycle

Parameter: P85

Menu path: SERVICE / SIMULATION / TIME

Description: Cycle time of the simulation

Default value:
60 sec

Bottom value of the simulation

Parameter: P86

Menu path: SERVICE / SIMULATION / BOTTOM VALUE

Description: Lowest value of the simulation

Default value:		
pH measurement	ORP measurement	DO measurement
0 pH	- 1000 mV	0 ppm

Upper value of the simulation

Parameter: P87
 Menu path: SERVICE / SIMULATION / UPPER VALUE
 Description: Highest value of the simulation

Default value:		
pH measurement	ORP measurement	DO measurement
14 pH	1000 mV	8.24 ppm

6.4.5.8 Temperature simulation

This function helps the user to check the outputs and the additional processing instruments connected to the output.
 To start simulation the instrument must return to Measuring mode.

Temperature simulation mode

Parameter: P84: b
 Menu path: SERVICE / TEMP. SIMULATION / MODE

Default value:
OFF

Description: Temperature simulation mode:

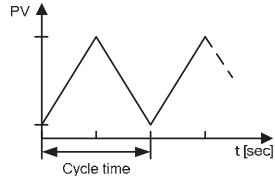
OFF	No temperature simulation	
FIX VALUE	Simulation of a fixed lower range temperature value	
TRIANGLE WAVE	The simulated value changes linearly between the set low and high values with an adjustable cycle time	

Temperature simulation cycle

Parameter: P88
Menu path: SERVICE / TEMP. SIMULATION / TIME
Description: Cycle time of the temperature simulation

Default value:
60 sec

Bottom value of the temperature simulation

Parameter: P89
Menu path: SERVICE / TEMP. SIMULATION / BOTTOM VALUE
Description: Lowest value of the temperature simulation

Default value:
0 °C

Upper value of the temperature simulation

Parameter: P90
Menu path: SERVICE / TEMP. SIMULATION / UPPER VALUE
Description: Highest value of the temperature simulation

Default value:
50 °C

6.4.5.9 Load default values

Parameter: -
Menu path: SERVICE / DEFAULTS / LOAD DEFAULT
Description: This command loads all default values of the instrument.
After loading the default values the parameters can freely be changed, the effect of the changes does not affect the measurement until the user exits programming mode and returns to measurement mode. Before loading the defaults the software asks for a confirmation warning the user that all user parameters will be lost!

Default value:
-

6.4.5.10 Restart

Parameter: -
Menu path: SERVICE / RESTART
Description: Restarts the instrument (Cold boot) (Reloads parameters from the non-volatile memory)

Default value:
-

6.5. PH SENSOR CALIBRATION

This function is for periodic calibration of the pH sensor.

Entering the SERVICE / SENSOR CALIBRATION menu the instrument will display a warning message that the user is about to change critical parameters of the measurement system. The user can enter the menu by pressing the \odot (OK) button or exit to the previous menu by pressing the \ominus (NO) button.

In case of calibration, after sensor replacement, please handle first calibration with high priority. The system will inquire this in the next dialog box. In the event of initial calibration, press the \odot OK button. In this case, all parameters and counters related to the sensor will be reset to default.

We should press \ominus NO button, in case it is not the first calibration.

In the SENSOR INFO page the slope and offset voltage of the sensor can be checked (see chapter 6.2).

The calibration can be performed within ± 0.8 pH sensor error. When this error is greater than ± 0.8 pH the unit shows a warning message that the sensor should be replaced.

6.5.1. Editing one item of the calibration table

(SERVICE | SENSOR CALIBRATION | VIEW/EDIT TABLE)

Calibration of the pH sensor is done using this table with min. 2 or max. 8 elements. By default the table contains 2 elements (0 and 14pH). The instrument is ready to measure with these two elements in the table. Any change in the calibration table applies instantly! The two minimal elements of the table cannot be erased only edited.

The selected element of the list (table) can be edited by pressing the $\text{\textcircled{E}}$ button. Then we get a special box editor.

One line of the list consists of two values. The left one (BUFFER VALUE) shows the nominal value of the used pH buffer solution. The right one (SENSOR VALUE) indicates the uncalibrated but temperature compensated value measured with this buffer solution.

VIEW/EDIT TABLE		
0:	0.00	0.00
1:	14.00	14.00

Adding, modifying a calibration point

The following special screen helps the user to set a calibration point. The user can see the uncalibrated measured values and also the pair values of the selected table line.

1. Value, measurable without sensor calibration
2. Trend display for monitoring installation.

The upper part of the bargraph symbolizes the increasing trend, the bottom part of the bargraph symbolizes the decreasing trend. The filling rate is in accordance with the measure of change. If the bargraph is empty, the measured value is constant.

3. Measured value with calibration.
4. The BUFFER VALUE is editable using the \uparrow , \downarrow and \leftarrow buttons. The user has to enter the nominal pH value of the measured buffer solution.
5. The measured value can be copied to the stored SENSOR VALUE by pressing the \uparrow + \downarrow buttons simultaneously. Then the software starts an algorithm to check if the measured value is stable or not. When the value is stored in the SENSOR VALUE field, a READY message appears on the bottom of the display.

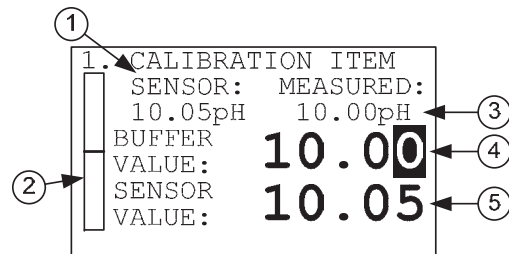

The measured value can be copied to the stored SENSOR VALUE by pressing the \uparrow + \downarrow buttons simultaneously. If the two values of the data pair differ in more than ± 0.8 pH from each other the software shows an error message at the bottom line of the screen.

By pressing the E button the instrument checks the edited calibration data pair and if it is OK the software returns to the calibration table. If not a dialogue window will appear and inform the user.

Exit from the calibration table by pressing the \leftarrow button.

Damping check:

When pressing the \uparrow + \downarrow buttons the software checks if the calibration value to be stored is constant. After the buttons are pressed the measured pH value must be stabilized in 30 seconds otherwise the value will not be stored and a FAILED! message will appear on the screen. Change in the measured value (1) can be followed on the trend bargraph (2). If the cause of a fluctuation or error is eliminated, storing of the calibration points can be repeated by pressing the \uparrow + \downarrow buttons again.

6.5.2. Adding an item to the calibration table

(SERVICE | SENSOR CALIBRATION | ADD ITEM)

This menu point adds a line to the table and enters to view/edit table display at the same time. Editing is done as described above.

6.5.3. Deleting an element of the calibration table

(SERVICE | SENSOR CALIBRATION | DELETE ITEM)

This menu point lets the user delete a line (element) of the table. Pressing the \ominus on the selected line deletes it from the table. Exit from the list by pressing the \leftarrow button.

DELETE ITEM		
0:	0.00	0.00
1:	7.01	7.05
2:	14.00	14.00

6.5.4. Reset the calibration table to default

(SERVICE | SENSOR CALIBRATION | RESET TO DEFAULT)

This function resets the sensor calibration data to default (0 and 14 pH). It is ineffective to other operating parameters.

6.5.5. Calibration procedure

1. Enter to menu point „**SENSOR CALIBRATION - VIEW / EDIT TABLE**” as described in Chapter 6.5.1
2. Rinse the pH electrode and temperature sensor with distilled water then dry up gently using a soft rag.
3. Immerse the electrode as well as the temperature sensor into the buffer solution.
4. Select one existing line of the calibration table or add a new item to the table.
5. In the „**BUFFER VALUE:**” field enter the pH value of the first buffer solution corrected to the actual temperature – use the \uparrow , \downarrow and \leftarrow buttons - . (The temperature corrected pH values of the buffer solution usually are listed on the label of the bottle.)
6. Observe the damping of „**SENSOR:**” and „**MEASURED:**” values. This is helped by the bargraph near them. If values are settled press \uparrow + \downarrow buttons simultaneously to store the actual measured value which will appear in the „**SENSOR VALUE:**” field. If user cannot get a clear measurement (the value is constantly changing) the sensor should be cleaned as described in chapter 4.3 and recalibrated again. If the electrode still cannot be calibrated it has to be replaced with a new one!
7. Exit to „**VIEW / EDIT TABLE**” by pressing the \ominus button.
8. Repeat steps 2...6 for every desired calibration point (max. 8)
9. Exit programming mode by pressing the \leftarrow display, and check the calibrated measurement state („**UNCAL**” message disappears from the display).

6.6. DO SENSOR CALIBRATION

This function is for periodic calibration of the DO sensor.

The sensor is aging during the usage of the instrument. When the life-time of the sensor is over the sensor should be replaced. In case of sensor replacement the sensor should be calibrated compensating the aging. Calibration of the sensor has to be done in two points: (ZERO – zero point and SPAN – saturated value)

ZERO calibration can be performed with 5% sodium sulphite referential liquid, SPAN (saturated value) calibration can be performed with saturated zero salinity referential liquid or air. Value of atmospheric pressure should be set before calibration process (see 6.4.1.8.)

Entering the SERVICE / SENSOR CALIBRATION menu the instrument will display a warning message that the user is about to change critical parameters of the measurement system. The user can enter the menu by pressing the \odot (OK) button or exit to the previous menu by pressing the ∇ (NO) button.

In case of calibration, after sensor replacement, please handle first calibration with high priority. The system will inquire this in the next dialog box. In the event of initial calibration, press the \odot OK button. In this case, all parameters and counters related to the sensor will be reset to default.

We should press ∇ NO button, in case it is not the first calibration.

6.6.1. Calibration of saturated value (100%)

(SERVICE / SENSOR CALIBRATION / CAL. IN AIR (SPAN))

Rinse the DO sensor with distilled water then dry up gently using a soft rag. Immerse the sensor into saturated, zero salinity referential liquid or hold the sensor into air.

Please wait until the measured value (2) get stabilized. Change in the measured value (2) can be followed on the trend bargraph (1). Achieving proper calibration atmospheric pressure (3) and relative humidity (4) should be entered. In accordance to these values and the measured temperature the instrument calculates the DO concentration, which can be edited in the last line (5).

Damping check:

When pressing the E button at the last line, a warning message appears asking do we really want to store the calibration data. By pressing the \odot [yes – OK] button, the instrument checks the stability of the measured value and if it remains unchanged during a given time period, the instrument stores the calibration. Changes of the measured value can be checked on the display (2) and the trend bargraph (1) also indicates changes of the measured value. When the measured value got stabilized, READY! message will appear on the bottom of the screen. If damping check procedure is unsuccessful, FAILED! message will appear on the bottom of the screen. When the error caused by changes or fluctuations became resolved, then calibration-point storing procedure can be repeated.

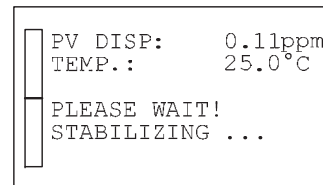
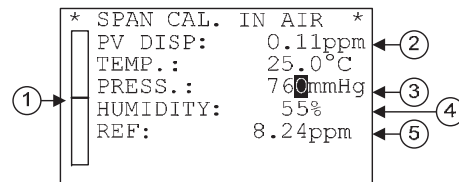

6.6.2. Calibration of Zero point (0%)

(SERVICE / SENSOR CALIBRATION / CAL. IN ZERO SOL.)

Rinse the DO sensor with distilled water then dry up gently using a soft rag. Immerse the sensor into 5% sodium sulphite referential liquid.

Please wait until the measured value (2) get stabilized. Change in the measured value (2) can be followed on the trend bargraph (1).

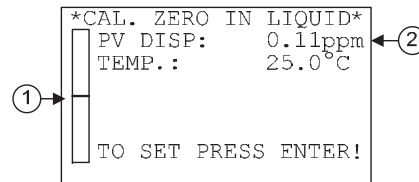

When pressing the E button at the last line, a warning message appears asking do we really want to store the calibration data. By pressing the OK button we enter the damping check procedure described in the previous point.

6.6.3. Calibration with referential DO instrument

(SERVICE / SENSOR CALIBRATION / CAL. IN SPAN SOL.)

With this function the instrument can be calibrated to a referential (already calibrated) instrument. In this case basic settings (atmospheric pressure, temperature) should be the same.

Rinse the DO sensor with distilled water then dry up gently using a soft rag. Immerse the sensor into saturated referential liquid with zero salinity or hold the sensor into air.

Please wait until the measured value (2) get stabilized. Change in the measured value (2) can be followed on the trend bargraph (1).

Read the measurement value of the referential instrument and enter this value to the edit field (3).

When pressing the E button at the last line, a warning message appears asking do we really want to store the calibration data. By pressing the OK button we enter the damping check procedure described in 6.6.1 point.

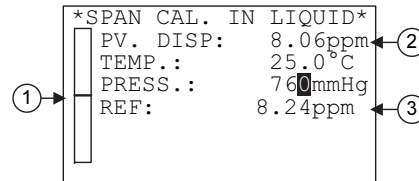

6.6.4. Reset the calibration table to default

(SERVICE | SENSOR CALIBRATION | DELETE ITEM)

This function resets the sensor calibration data to default. It is ineffective to other operating parameters.

6.6.5. Reset Timer

This function resets the inner timer of the DO electrode life-time monitoring routine.

6.7. ERROR CODES

Code	Message on the screen	Error description	Procedure
1	MEMORY ERROR	Memory error in the electronics	Contact the service!
2	NO INPUT SIGNAL	Hardware error	Contact the service!
3	EE COM. ERROR	Hardware error	Contact the service!
4	MATH. OVERLOAD	Display overflow	Check the programming!
5	SENS. SERVICE!	Sensor slope and offset are out of tolerance limit.	Check or clean the sensor and do a calibration. Check the correct operation of the sensor and the installation!
16	EE CHK ERROR	Parameter checksum error.	Restart the unit in SERVICE / RESTART menu (or power off and on the instrument) and check / repeat programming! If the problem persists contact the service!
17	INTEGRITY ERROR	Incorrect parameter values. Stored parameters are damaged.	Restart the unit in SERVICE / RESTART menu (or power off and on the instrument) and check / repeat programming! If the problem persists contact the service!
18	AC COM. ERROR	Hardware error	Contact the service!
19	RELAY ERROR	Hardware error	Contact the service!
-	TEMP. ERROR	Temperature sensor error	Check the connection of the temperature sensor. The unit will compensate to 25°C!
-	CALIBRATION ERROR	Logic error	Check the sensor calibration table!
-	POINT PAIR ERR.	Logic error	Check the sensor calibration table!

6.8 MENU MAP

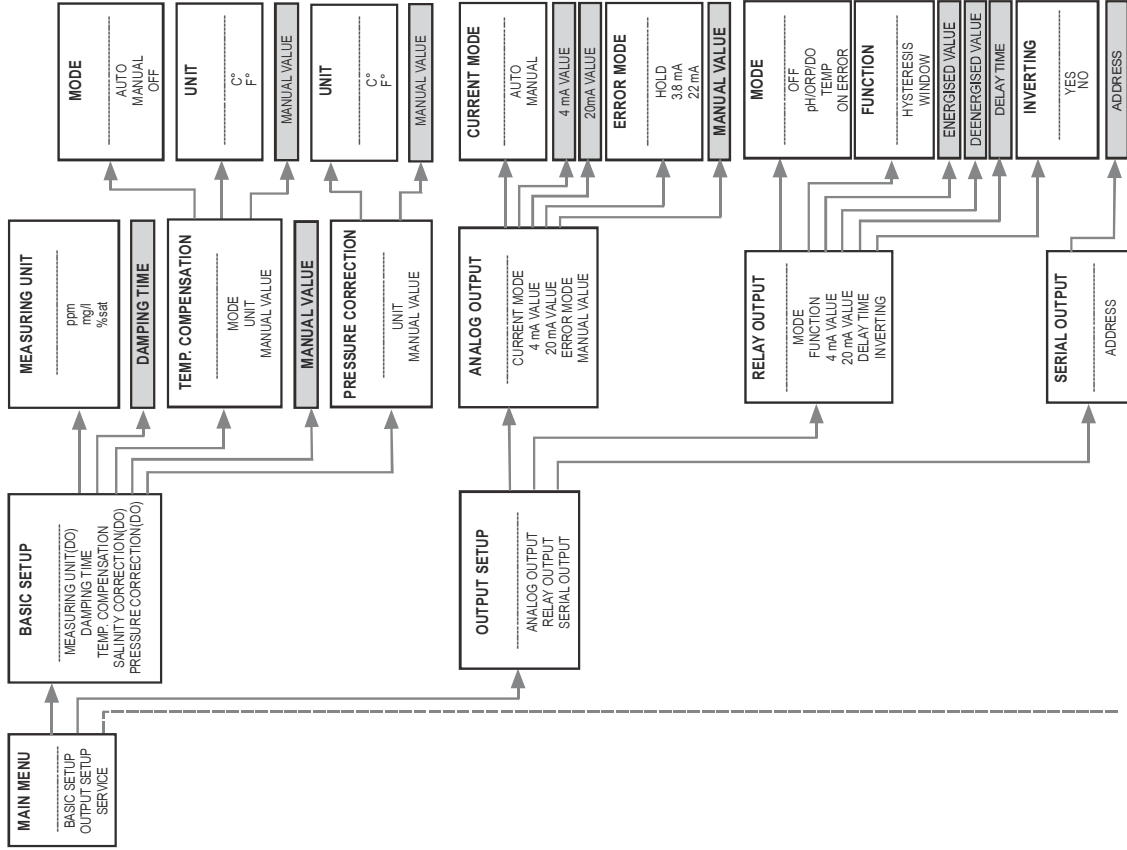

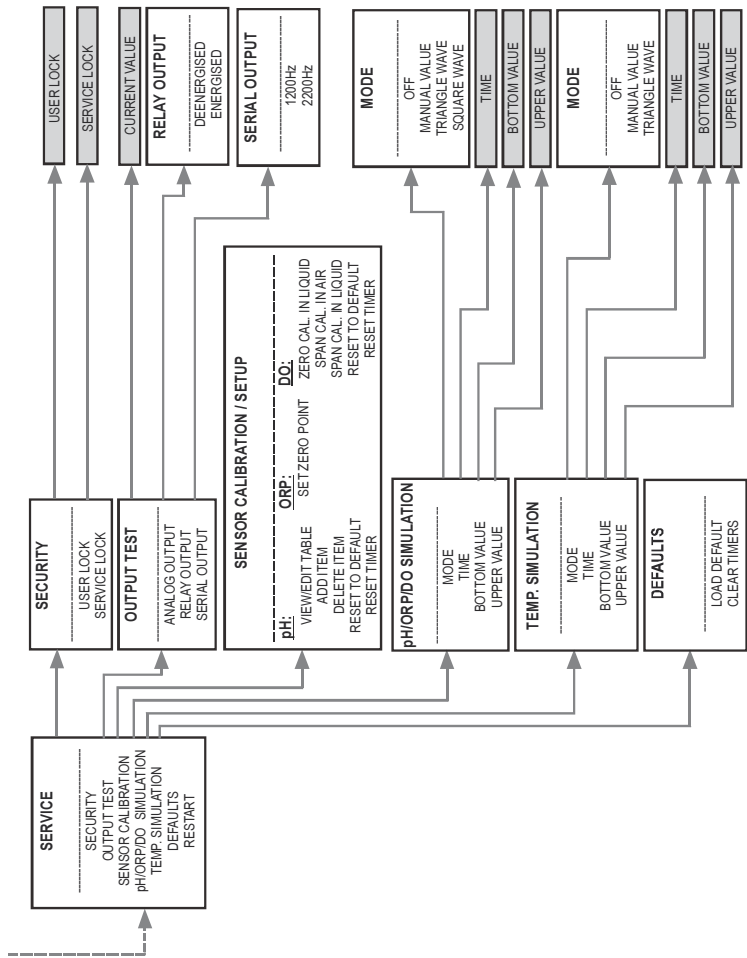

64 / 64 ♦ le00100a0600p_06 ♦ BKI 11 ATEX 0012 X



Distribuidora Autorizada: NIVETEC Instrumentação e Controle Ltda
Tel.:(11) 2627-6600 | comercial@nivetec.com.br | www.nivetec.com.br