

NivoTRACK

NIVELCO - Transmissor de Nível (integrado)



Confira
todos
nossos
produtos!

nivetec.com.br

NIVETEC

BASIC CONCEPT OF MEASUREMENT

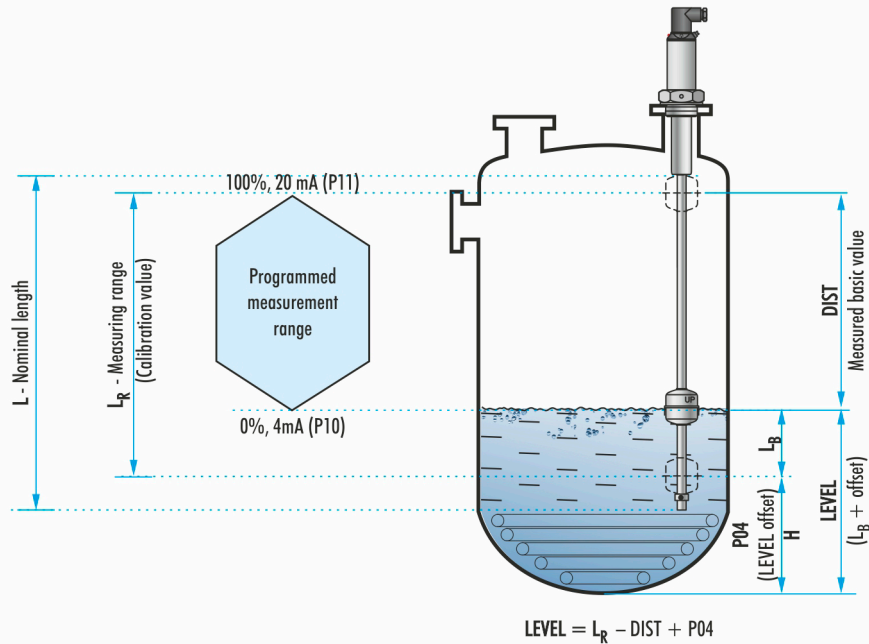



TABLE OF CONTENTS

1. INTRODUCTION	6
2. ORDER CODE	7
2.1. ACCESSORIES TO BE ORDERED	8
2.2. FLOAT SELECTION.....	8
3. TECHNICAL DATA.....	9
3.1. MEASUREMENT DATA (MSZ EN 60770-1:2011, MSZ EN 61298-1:2009, MSZ EN 61298-3:2009)	10
3.2. DIMENSIONS	11
3.3. ACCESSORIES	12
4. INTEGRATION INTO THE TECHNOLOGICAL PROCESS (INSTALLATION, WIRING)	12
4.1. WIRING	13
5. PROGRAMMING	13
6. MAINTENANCE AND REPAIR	16
7. STORAGE CONDITIONS	16

*Thank you for choosing a NIVELCO instrument.
We are sure that you will be satisfied throughout its use!*

1. INTRODUCTION

Application

NIVOTRACK MI□-, MX□-, MY□-5□□ series working on the magnetostrictive principle are suitable for high accuracy level measurement of storage tanks. Due to their high temperature and pressure rating these units can also be used for level gauging of technological tanks. The 2-wire magnetostrictive level transmitters are an ideal solution for high accuracy measurement of clean fluids.

Operating principle

The magnetostrictive transmitter is using the special feature of the magnetostrictive wire spanned in the rigid probe. A magnetic field excited in the magnetostrictive wire develops an acoustic wave in the wire. From the interference point with the magnetic disc placed in the float the wave travels back to the electronics with defined velocity. Measurement is based on the time of flight of the acoustic wave since it is proportional with the distance of the float from the electronics.

The above distance constitutes the basis for all output signals of the NIVOTRACK! With the help of further mechanical data level can be calculated.

2. ORDER CODE (NOT ALL COMBINATIONS POSSIBLE!)

NIVOTRACK M - 5 -

TYPE	CODE	PROBE / PROCESS CONNECTION	CODE	HOUSING	CODE	CODE	PROBE LENGTH (m / ft)	CODE	OUTPUT	CODE
Transmitter	I	1" BSP	A	Stainless steel	5	0	0 / 0	0 / 0	4...20 mA + HART® / 1 mm (0.039") / DIN connector	M
Transmitter mini	Y	1" BSP lower connection	B			1	1 / 3.3	0.1 / 0.33		
Transmitter with plastic coating	X	2" BSP	C	2	2 / 6.6	0.2 / 0.66	2			
		2" BSP lower connection	F	3	3 / 10	0.3 / 1	3			
		1" NPT	D			0.4 / 1.33	4			
		1" NPT lower connection	E			0.5 / 1.66	5			
		2" NPT	G			0.6 / 2	6			
		2" NPT lower connection	H			0.7 / 2.33	7			
		1 ½" Triclamp	J			0.8 / 2.66	8			
		2" Triclamp	M			0.9 / 3	9			
		2 ½" Triclamp	O							
		3" Triclamp	P							
		4" Triclamp	R							
		Without float, for NIVOFLIP	L							
		Without process connection	U*							

* Process connection to be ordered separately

Minimal nominal length: 300 mm (11.8")

2.1. ACCESSORIES TO BE ORDERED

THREADED SLIDING SLEEVE

TYPE	CONNECTION	S (mm / ")	H (mm / ")	L (mm / ")	B (mm / ")		
MBH-105-2M-300-00	1" BSP	41 / 1.61	36 / 1.42	20 / 0.78	-		
MBK-105-2M-300-00	2" BSP	60 / 2.36	55 / 2.17	24 / 0.94	-		
MBL-105-2M-300-00	1" NPT	41 / 1.61	37 / 1.46	-	~10 / 0.39		
MBN-105-2M-300-00	2" NPT	60 / 2.36	44.5 / 1.75	-	~11 / 0.43		



ATTENTION! During installing or removing the device when screwing the sliding sleeve into or out of the flange, make sure that the measuring tube is not twisted as this may cause the device malfunction. Hold the rigid tube section to prevent the unit from turning. Do not loosen the sliding sleeve when the tank is under pressure!

2.2. FLOAT SELECTION

TYPE	MBA-505-2M-600-00 ⁽¹⁾	MBA-505-2M-800-00 ⁽¹⁾	MBA-505-2M-200-00 ⁽¹⁾	MBK-505-		MBA-505-2M-900-00 ⁽²⁾	MGU-505-2M-200-00	MGU-505-1M-200-00	4w34bs-16yyyyy ⁽³⁾
				2M-400-00 ⁽²⁾	2M-800-00 ⁽²⁾				
Dimensions									
Min medium density (Specific gravity)	0.45 kg/dm ³	0.55 kg/dm ³	0.8 kg/dm ³	0.55 kg/dm ³	0.4 kg/dm ³	0.4 kg/dm ³	0.7 kg/dm ³	0.4 kg/dm ³	0.8 kg/dm ³
Material	Titanium		1.4404 (316L)	1.4435 (316L)	Titanium	1.4401 (316)	PVDF	PP	1.4404 (316L)
Medium pressure	20 bar (2 MPa, 290 psi)	25 bar (2.5 MPa, 362.5 psi)		6 bar (0.6 MPa, 87 psi)		3 bar (0.3 MPa, 43.5 psi)		10 bar (1 MPa, 145 psi)	

⁽¹⁾ Designed for min. 2" process connection, only order with rigid probe, not available for MY type.

⁽²⁾ Flange to be ordered separately, not available for MY type.

⁽³⁾ Designed for min. 1" process connection, only available for MY type.

If the float removed, when reinstalling it, make sure that the "UP" marking is on the top of the float. Ensures that the float is mounted back in the correct position and that the fastening nut is securely fixed in the position before dismantling. If a float larger than 2" is used, it is recommended to order a pre-mounted flange.



ATTENTION! If the fastening nut is not secured properly, the float may slide off the measuring tube when the tank is empty, causing the instrument to be unable to measure!

3. TECHNICAL DATA

TYPE	STANDARD MI□	MINI MY□	PLASTIC COATED VERSION MX□
Measured process value	Liquid level, distance		
Nominal length (L)	0.3...3.5 m (1...11.5 ft)	0.3...1.5 m (1...4.9 ft)	0.3...3 m (1...10 ft)
Material of the tube	Stainless steel: DIN 1.4571		PFA coated, Stainless steel: DIN 1.4571
Max. medium pressure*	25 bar (2.5 MPa, 360 psi)	16 bar (1.6 MPa, 230 psi)	3 bar (0.3 MPa, 43.5 psi)
Medium temperature*	-40...+90 °C (-40...+194 °F)		
Standard float diameter / material (included)*	∅54 x 60 mm (∅2.1 x 2.36") cylindrical / 1.4404 (316L)	∅28 x 29 mm (∅1.1 x 1.15") / 1.4404 (316L)	∅76 x 87 mm (∅3 x 3.4") cylindrical / PVDF
Medium density	∅54 mm (∅2.1") float min. 0.8 g/cm ³ ; ∅54 mm (∅2.1") Titanium float min. 0.55 g/cm ³ ∅95 mm (∅3.74") float min. 0.55 g/cm ³ ; ∅124 mm (∅4.88") float min. 0.4 g/cm ³		PVDF float min. 0.7 g/cm ³
Material of wetted parts	Stainless steel: 1.4571 (316Ti), floats: see "Float Selection"		PFA, PVDF, PP
Ambient temperature	-40...+70 °C (-40...160 °F)		
Output	Analogue		4...20 mA (limit values: 3.9...20.5 mA)
	Digital communication		HART® (minimum loop resistance: 250 Ω)
Error indication	Output signal = 22 mA or 3.8 mA		
Output load	$R_L = (U_S - 12.5 V) / 0.02 A$; U_S = power supply voltage		
Power supply	12.5...36 V DC		
Electrical protection	Class III		
Ingress protection	IP65		
Process connection	As per order code		
Electrical connection	Hirschmann EN 175 301-803-A (DIN43650)		
Weight	2.9 kg + measuring probe: 0.6 kg/m (6.4 lb + m. probe: 0.4 lb/ft)	2.9 kg + measuring probe: 0.3 kg/m (6.4 lb + m. probe: 0.2 lb/ft)	2.9 kg + measuring probe: 0.7 kg/m (6.4 lb + m. probe: 0.47 lb/ft)

*Details of non-standard floats can be found under "2.2 Float Selection".

3.1. MEASUREMENT DATA (MSZ EN 60770-1:2011, MSZ EN 61298-1:2009, MSZ EN 61298-3:2009)

TYPE	M□□-5□□-□
Resolution (on HART® transmitted value)	1 mm (0.04")
Nonlinearity (on HART® transmitted value)	±2 mm (±0.08") or ±0.085% whichever is greater Under reference conditions
Hysteresis (under reference conditions)	±0.25 mm (±0.01")
Zero span (in LEVEL measurement mode)	Anywhere within the active range
Measurement range (reducing)*	Minimal range: 32 mm (1.26"), Maximum range: see *3.2 Dimensions"
Temperature error	0.04 mm (0.0016") / 10 °C (18 °F) (between -25...+50 °C [-13...+122 °F])
Current output resolution	0.4 µA
Current output accuracy	33 µA
Current output temperature error	6 ppm / °C

* The accuracy data is only valid for factory default settings!

3.2. DIMENSIONS

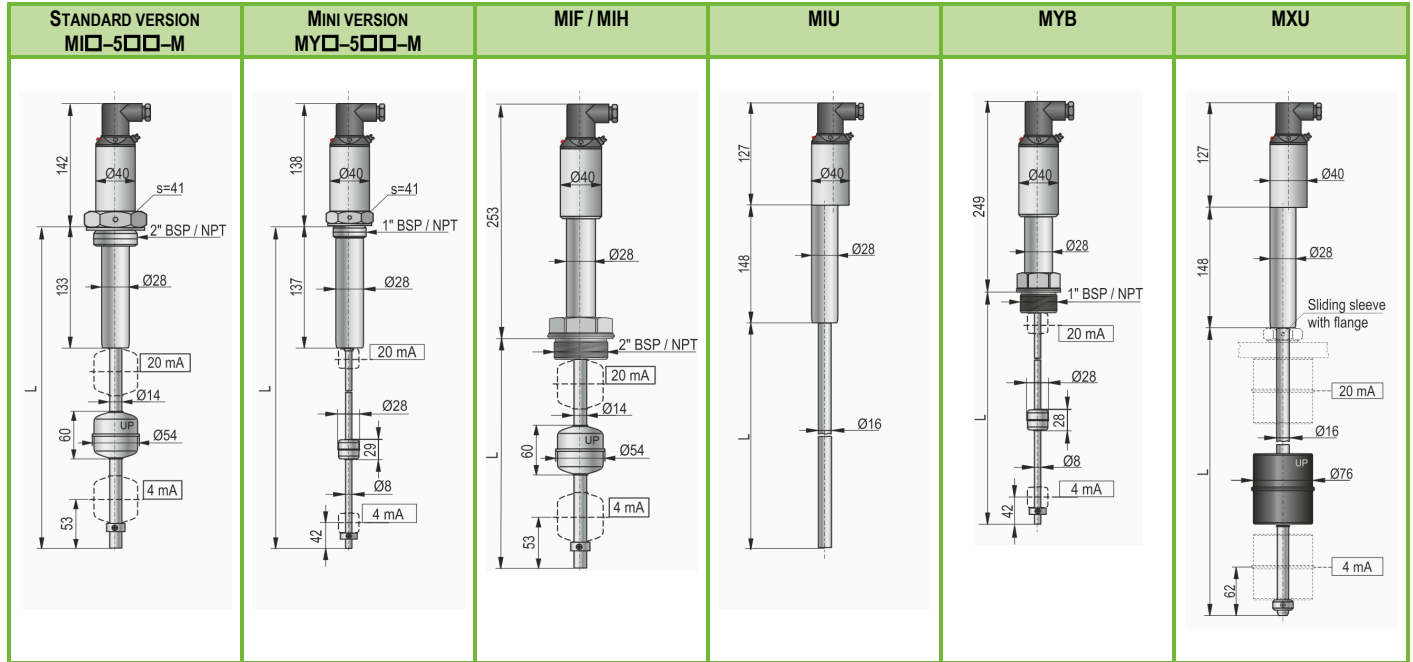

3.3. ACCESSORIES

- User's and programming manual
- Warranty Card
- EU declaration of conformity
- 1 x gasket (klingerit oilit) for BSP threads only

4. INTEGRATION INTO THE TECHNOLOGICAL PROCESS (INSTALLATION, WIRING)

- When choosing the installation place please ensure proper space for later calibrations, verification or maintenance service.
- Waving, vortex or vibration effects have negative influence on the measurement accuracy. To avoid these effects, the mounting placement should be as far as possible from the sources of these disturbing effects for instance from openings of filling or emptying. These effects can be attenuated in applications with rigid tube probes by the use of stilling pipe along the whole probe. Please consult with a NIVELCO distributor!
- To ensure consistent and durable operation the measurement medium should be free of suspended solid materials, which could stick between the float and the probe.

- **The unit should be protected against direct heat radiation.**
- Prior to the installation the mounting dimensions of the unit and the tank as well as the calculations should be checked carefully.
- Prior to the installation a preliminary operation check is suggested.
- If necessary to change the default factory settings the programming should be performed in accordance to the description in the 5th chapter.
- The units are offering a wide variety of process connections according to the available order codes. The tank opening should be fit for the selected level transmitter by means of the insertion hole is bigger than the float diameter. If this is not possible the float has to be removed from the probe and when the unit is mounted into the tank the float can be mounted from inside of the vessel. The "UP" marking on the float ensures that the float is mounted back in the correct position. See the drawing! Prior to finishing the mounting the spacer needed to assemble back between the float and the counterweight.



ATTENTION!

In order to avoid damaging the probe, do not put it to torsion when installing or removing the unit. Therefore, special care has to be taken when the process connection is being screwed into or out of the flange. The best is to hold the rigid part of the probe with a suitable tool as long as the process connection is tightened to its place. Sliding sleeve must not be loosened during operation.

4.1. WIRING

This transmitter is designed to operate on 12.5...36 V DC power only.

The measured voltage on the terminals of the unit should be at least 12.5 V. Using transmitter with HART® a terminal resistance with a minimum value of 250 Ω should be applied.

CAUTION! the enclosure of the transmitter should be grounded. Grounding resistance should be $R \leq 1 \Omega$. Shielding of the interconnecting cable should be grounded at the control room side. To avoid disturbing noises the interconnecting cable must not be led near to high voltage cables. Especially critical are inductive couplings of AC harmonics against which the protection of shielding is not effective.

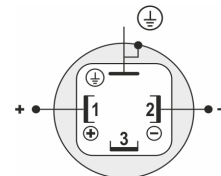

5. PROGRAMMING

LED display:

- continuously lit: normal operation
- off, 1 brief flash: no echo
- off, 2 short flashes: excitation signal generation error
- off, 3 short flashes: current generator fault, current output does not match device set program
- lit, 1 short-term non-lighting: saturation

Parameters can set using a HART® modem, EView2, or PACTware™ program or MultiCONT process controller.

Parameters are entered as 4 place value decimal numbers for the parameters where it's indicated. Indication of each place value ' d c b a ', unused place values in the description: (-). The instrument ignores unused place values.

P0: - c b -: Measuring unit, Dimension of the measuring unit

Parameter: **P0:c**, Measuring unit

Description: This should be configured as the first step of the programming. Here you can choose the default unit system:

- c = 0: EU – European unit system
- c = 1: US – Anglo-Saxon unit system

Default measuring unit system: c = 0: EU

Parameter: **P0: b**, Dimension of the measuring unit

Description: The dimension of the unit can be specified in this menu:

- EU European unit system: b = 0: m; b = 1: cm; b = 2: mm
- US Anglo-Saxon unit system: b = 0: ft; b = 1: inch

Default measuring unit: b = 2: mm

ATTENTION! If the unit system or measuring unit is changed, after a warning message the device resets all the parameters.

P1: - - a: Primary value (PV) source

Parameter: P1: a

This mode determines the primary value and the displayed value. It also determines the value which will be proportional to the output current.

- a=0: DISTANCE
- a=1: LEVEL

Default value: a=0 (DISTANCE)

P4: Zero-point offset

Description: This Parameter is used for zero-point offset. In level measurement mode the zero level is meant at the lowest position of the float. Due to the construction of the device, it cannot able to measure the level through the whole height of the tank, because it may not reach the bottom of the tank. In this Parameter the distance between the lowest position of the float and the bottom of the tank can be entered.

The offset value will be a negative value (the value of the Parameter is always the distance between the lowest position of the float and the zero-point offset of the measurement) this negative number should be entered into the Parameter if the measurement range needs to be decreased virtually. The absolute value of this number shall be less than the active measurement range. Wrong configuration of the zero-point offset can result negative level display. The current output can go below 4 mA, but saturates at 3.9 mA.

If there is no need to use Zero-point offset, enter zero in the parameter.

Default value: 0.

P8: Fixed output current

Description: Parameter for setting the fixed output current, but this only appears on the output when parameter P12: b is set to MANUAL.

Values between 3.8 and 20.5 can be entered. The output current will be set to the entered value and analogue transmission will be suspended. This error indication overrides all other error indication.

Default value: 4 mA

P10: Output current value 4 mA

Description: Measured value assigned to 4 mA. The transmitted value is in accordance to the primary value (PV) (P01:a).

Assignment can be done that the change in measured value and the change in the output value are the same (normal), or opposite directional (inverse operation). For example: 1 m level is 4 mA, 10 m level is 20 mA, or 1 m level is 20 mA and 10 m level is 4 mA.

Default value: 0 mm

P11: Output current value 20 mA

Description: Measured value assigned to 20 mA. The transmitted value is in accordance to the primary value (PV) (P01:a). Assignment can be done that the change in measured value and the change in the output value are the same (normal), or opposite directional (inverse operation). For example: 1 m level is 4 mA, 10 m level is 20 mA, or 1 m level is 20 mA and 10 m level is 4 mA.
Default value: Maximum measurement range accordance to the nominal length of the device (mm).

P12: - - b a: Output current mode, Error mode

Parameter: P12: b, Output current mode

Description: Current transmitter mode [AUTO, MANUAL]

- b = 0: AUTO, output current value is calculated from the measured value.
- b = 1: MANUAL, The Output current is the fixed current set-in parameter P8. In this case, the output current error setting is not valid either!

Default value: AUTO

Parameter: P12: a, Error mode

Description: "Error indication" by the current output

- a = 0: HOLD, Error indication has no effect on the output current. In this case, it holds the last valid measurement result at the output.
- a = 1: 3.8 mA, Error indication: the output current gets 3.8 mA.
- a = 2: 22 mA, Error indication: the output current gets 22 mA.

Attention! This error indication is active unless the failure is fixed, or until the failure terminates.

Default value: HOLD

P19: HART polling address

Description: HART polling address of the device (0...15).

The polling address can be set between 0 and 15. For a single instrument the polling address is 0 and the output is 4...20 mA (analogue output).

If multiple units are used in HART Multidrop mode (max. 15 pcs.) the polling addresses should differ from 0 (1...15), in this case the output current will be fixed at 4 mA.

Default value: 0

P20: Damping time

Description: Damping time is used to damp the unwanted fluctuations of the output and display. If the measured value changes rapidly the new value will settle with 1% accuracy after this set time. (damping according to an exponential function).

Adjustable values: 0...99 sec.

Default value: 0 sec

6. MAINTENANCE AND REPAIR

NIVOTRACK M□□-5□□-□ units do not require maintenance on a regular basis. The warranty conditions are included in the warranty card.

Before returning the device for repairs, it must be cleaned carefully, the parts in contact with the medium that might contain harmful substances must be decontaminated. Our official form ([Returned Equipment Handling Form](#)) must be enclosed. Download it from our website www.nivelco.com. The device must be sent with a declaration of decontamination. Please provide a statement in the declaration that the decontamination process is completed, the device is clean and free from harmful materials, and there are no hazardous substances on it.

7. STORAGE CONDITIONS

Unused devices must be stored within the ambient temperature range specified in the technical data, and a maximum of 98% relative humidity.

mia505en2102p

June 2021

NIVELCO reserves the right to change technical data without notice!