



Instrumentação  
e Controle

# Catálogo



**NIVETEC INSTRUMENTAÇÃO E CONTROLE LTDA**

CNPJ: 66.747.627/0001-19

Tel: +55 (11) 2627-6600

E-mail: [comercial@nivetec.com.br](mailto:comercial@nivetec.com.br)

Rua das Flechas, 801 - Jardim Prudência, São Paulo - SP, 04364-030

[www.nivetec.com.br](http://www.nivetec.com.br)



SENSORS &  
CONTROLLERS



ANALYZERS  
& SAMPLERS



LEVEL, FLOW  
& PRESSURE



WEB APP &  
DATALOGGING



ACCESSORIES

# S401 DIFF/N DATASHEET

## PH ELECTRODE FOR PROHIBITIVE APPS

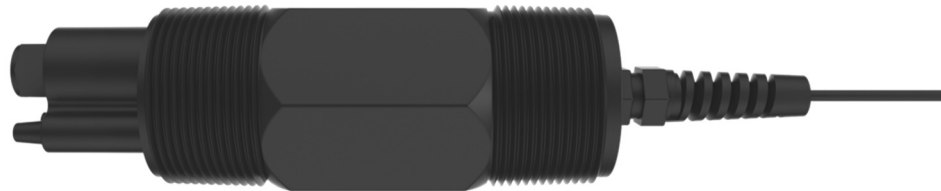

### MAIN FEATURES

- Reliable pH measure thanks to the use of a process of digital measurement
- Communication of measurements via MODBUS RTU protocol
- Differential method of measurement enables a longer electrode life in time and in the most prohibitive applications
- Possibility to execute all the calibrations via MODBUS RTU serial port
- Black RYTON® sensor body
- Absence of moving mechanical parts
- Immediate installation and easy maintenance

These sensors are fully interchangeable with any pH electrode and are suitable for use with any MODBUS RTU pH meter. They are able to communicate the values of the measure pH and Temperature via MODBUS RTU protocol, and you can perform all calibrations through the serial port.

### APPLICATIONS

S401 DIFF/N is used for differential measurement of pH in pure water, wastewater treatment plants, suspended solids fouling processes, processes with pollutants, processes with high concentrations of sulfides, coagulation and flocculation, scrubbers, galvanic processes, surface finishing, processes of elimination or recovery of heavy metals.

Designed for measurements of pH in heavy duty applications where pH electrodes standards would not be able to work because the life of reference would be too short.

The sensor is constituted by a RYTON® body which houses the glass electrode for measuring the pH, the reference electrode with a salt bridge, the temperature sensor, the earth contact of the solution and the electronic board of signal handling.

The S401 DIFF/N uses the proven technique of differential measurement in three electrodes, the pH and the reference electrode are compared to a ground electrode for a rate measuring accuracy, even in chemical applications difficult. The bridge replaced and the tank can be refilled ensure a long service life in applications containing sulphide (H<sub>2</sub>S) and metals such as lead, mercury, and silver.

## TECHNICAL DATA

Materials	• Ryton® body and saline bridge • Ceramic & PVDF junction • Viton® Orings • Platinum electrode • Glass membrane • Nylon and NBR cable gland
Measuring electrode	Hemispherical glass membrane
Thread	1-1/2 "NPT
Measuring ranges	0-14 pH
Measuring method	Differential
Stability	0.03 pH in 24 hours, not cumulative
Resolution	0.01 pH
Accuracy	± 0.01 pH
Repeatability	± 0.05 pH
Temperature probe	PT100
Operating temperature	Immersion: -5 ... 70°C (21 ... 158°F) Insertion: -5 ... 95°C (21 ... 203°F)
Max working pressure	6.9 bar
Minimum operating conductivity	50µS
Maximum absorption	1W
Cable	10m integral with sensor (more on request)
Mechanical protection	IP68 Sensor + cable
Power supply	12... 24Vdc
Communication	RS485 Modbus
Dimensions (LxHxP):	54x160x54mm

DIMENSIONS

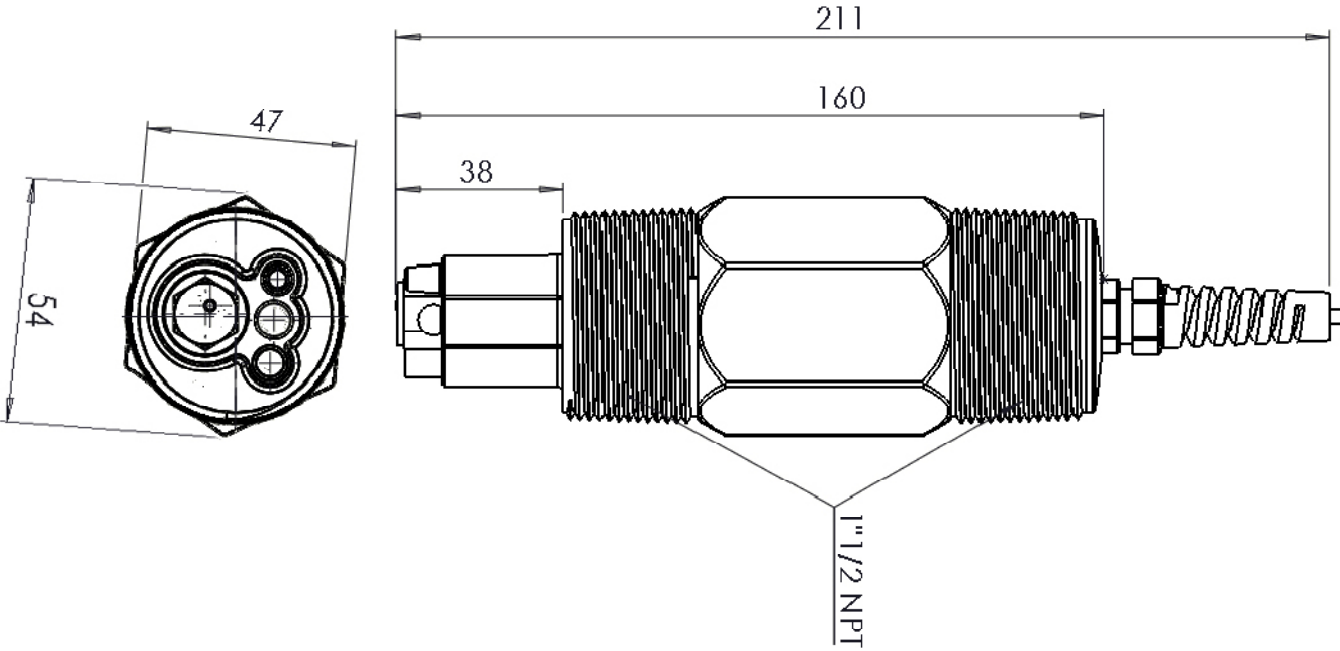

ORDER CODES

9701110097	S401/DIFF/N pH Electrode for prohibitive apps 10m cable
------------	---